

# PF-2000

## ■Features

1. No electrical equipment required since it utilizes inexpensive steam pressure or air pressure for operation.
2. Maintenance inspection is easily done due to main parts are attached to the cover.
3. Due to ultra-compact design, it can be installed without significant modification even in tight spaces.

## ■Specifications

Nominal size	25A	
Application	Steam condensate, Non-hazardous fluid	
Motive fluid	Steam / Air	
Max. working pressure	0.5 MPa	
Motive pressure	0.03 to 0.5 MPa	
Motive differential pressure	(Back pressure + 0.03 MPa) to 0.5 MPa	
Max. working temperature	160°C	
Material	Body	Ductile cast iron (FCD450)
	Trim parts	Stainless steel
	Float (P)	Stainless steel
Connection	JIS Rc screwed	
Check valve at inlet side	Built-in (swing type)	
Check valve at outlet side	Externally attached *2	

\*1 The most appropriate value of motive pressure is back pressure at outlet side + 0.1 to 0.2 MPa.

\*2 Install an optional check valve (SCV-2 or SCV-3) at inlet and outlet side of the product.



## ■Dimensions (mm) and Weights (kg)

<<Connection diameter>>

Condensate inlet	Condensate outlet	Motive pressure port	Vent port
Rc 1	Rc 1	Rc 1/2	Rc 1/2

Weight: 17kg

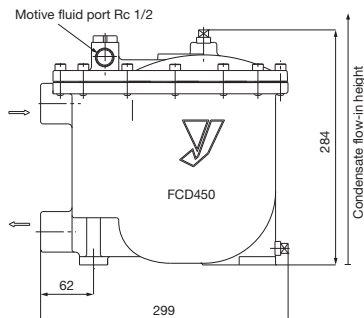
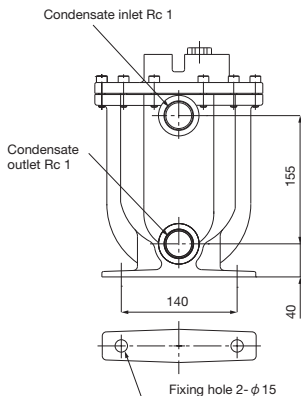
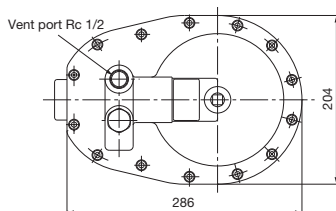

Please refer to P. 6-13.

## Flow rate

(kg/h)

Motive Pressure [MPa]	Back pressure [MPa]	Steam motive	Air motive
0.1	0.05	364	671
0.2		508	763
0.3		606	781
0.4		664	795
0.5		666	800
0.2	0.1	309	725
0.3		454	756
0.4		508	764
0.5	0.2	513	769
0.3		282	699
0.4		315	724
0.5	0.3	319	730
0.4		243	656
0.5		292	695
0.5	0.4	208	643

\* Flow rate described above indicates condensate volume when condensate flow-in height is 800 mm above bottom of the product.

## Flow Rate Correction Coefficient (Piping Example)

Discharge capacity varies depending on condensate flow-in-height. Multiply the volume by the following factors according to the condensate flow-in-height.

\* Condensate flow-in height means the height from the bottom of the product to bottom part of receiver.

Motive fluid	Condensate flow-in height [mm]				
	600	800	1000	1200	1400
Steam	0.90	1.0	1.05	1.10	1.15
Air	0.85	1.0	1.15	1.25	1.35

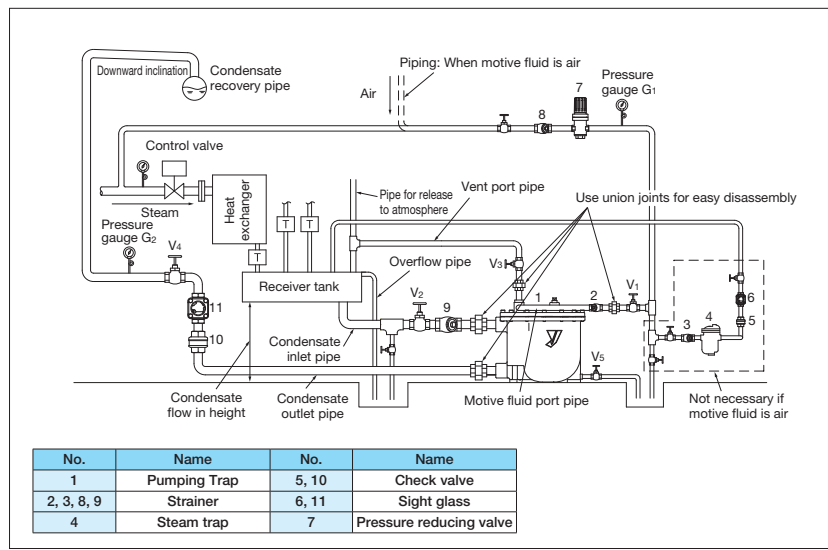

## Guidelines for Pumping Trap

Step  
3

## ■ Installation of receiver tank

Receiver tank is used for separation of flash steam and condensate, condensate temporary storage, protection of pumping trap, etc. Be sure to install receiver tank before using pumping trap.

## · Sizing of open receiver (open system)

Open receiver tank requires capacity to store condensate when pumping trap works and discharges condensate. Also, flash steam and condensate flows inside the condensate pipe at the same time, open receiver tank separates condensate from flash steam, and send only the condensate into the pumping trap. Therefore, open receiver tank requires dimensions enough to separate flash steam and condensate.

## 1) Calculate flash steam amount

1 Calculate flash steam ratio from usage condition, using the chart for condensate flash rate.

Ex) Condensate discharged from steam trap used in steam pressure 0.8 MPa to open receiver (atmospheric pressure), from the chart 1, flashes approximately 14%.

2 Calculate flash steam amount from condensate amount and flash rate. Flash steam Condensate amount Flash rate

Ex) If condensate amount is 1,000 kg/h, flash steam amount is  $1,000 \times 14/100 = 140\text{kg/h}$

## 2) Calculate diameter of receiver tank from flash steam amount.

(Standard length: 1 m)

Ex) From calculated flash steam amount and the chart 2, vent piping diameter is found as intermediate between 80A and 100A, then select 100A. In the same way, diameter of open receiver is 200A (length: 1 m).

## · Sizing of closed receiver (closed system)

Pumping trap requires capacity to store condensate temporarily during its operation. In relation to operation cycle, its capacity should be approximately 0.5% of condensate amount for an hour. For selection, use the chart 3.

Ex) If condensate amount is 1,000 kg/h, from the chart 3, when diameter of receiver tank is 80A, length is 1 m. When 100A, length is 0.65 m as a guide.

Chart 1 Flash rate of Condensate

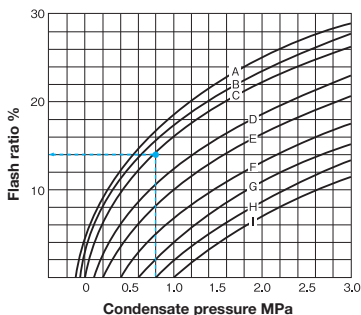

Code	A	B	C	D	E	F	G	H	I
Back pressure MPa	-0.05	-0.03	Atmospheric pressure	0.1	0.2	0.4	0.6	0.8	1.0

Chart 2 Sizing chart of open receiver

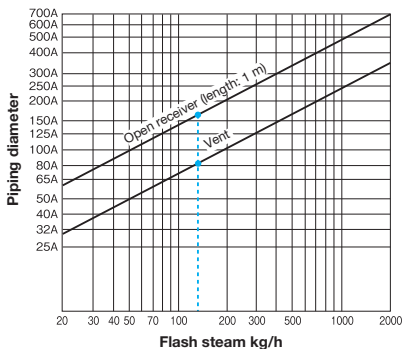

Chart 3 Sizing chart of closed receiver

