

Type 455, 456

Flanged Safety Relief Valves – spring loaded



Type 456
Packed lever H4
Closed bonnet
Conventional design

Contents	Chapter/Page
Materials	
• Conventional design	08/02
• Balanced bellows design	08/04
How to order	
• Numbering system	08/06
• Article numbers	08/08
Dimensions and weights	
• Metric Units	08/10
• US Units	08/11
Pressure temperature ratings	
• Metric Units	08/12
• US Units	08/13
Flange drillings and facings	08/14
Order information – Spare parts	08/15
Available options	08/16
Approvals	08/17
Capacities	
• Steam [Metric Units + US Units]	08/18
• Air [Metric Units + US Units]	08/19
• Water [Metric Units + US Units]	08/20
Determination of coefficient of discharge K_{dr}/α_w	08/21

Conventional design

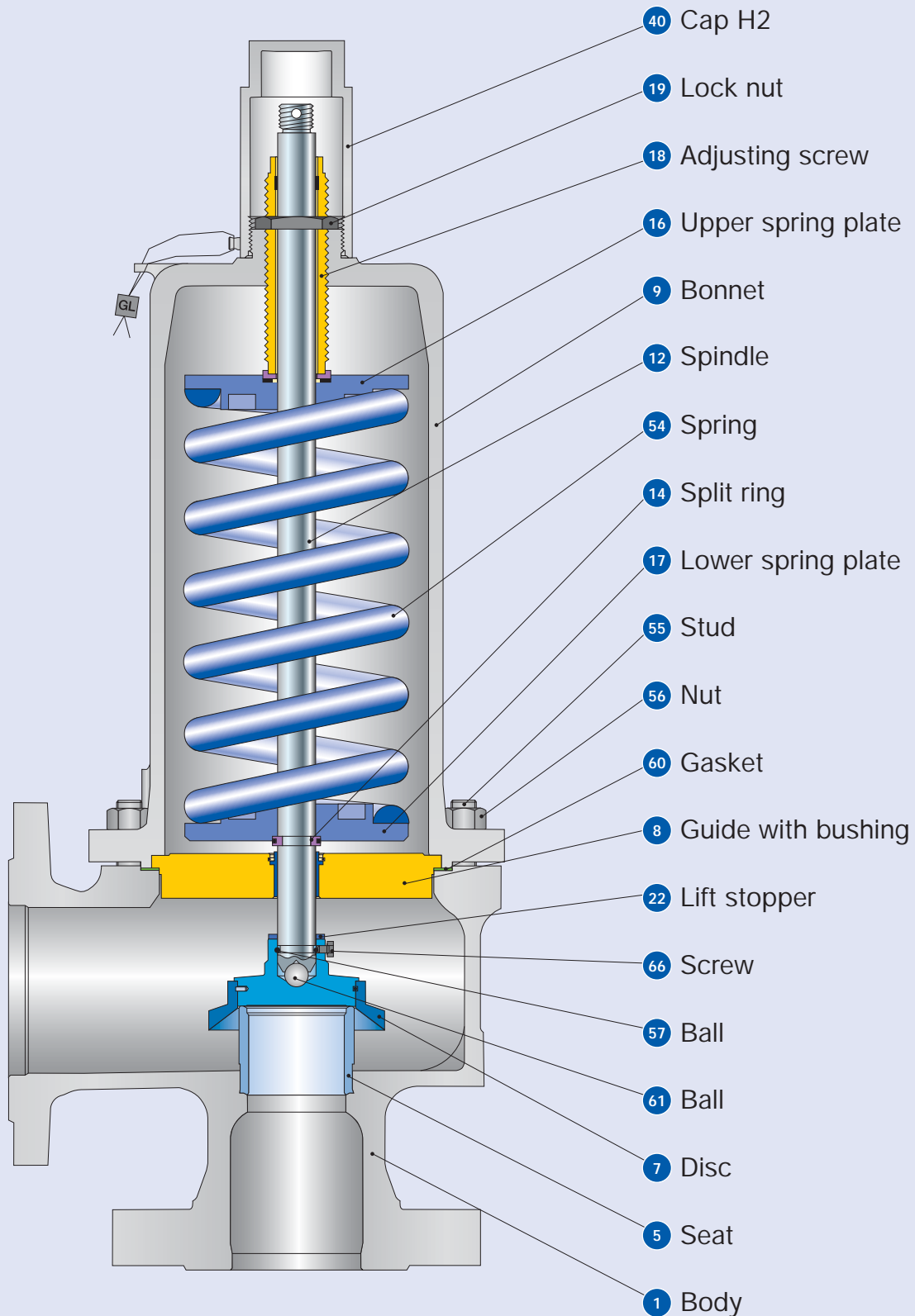

Conventional design

Materials			
Item	Component	Type 4552 / 4562	Type 4564
1	Body	1.0619	1.4581
		SA 216 WCB	SA 351 CF10M
5	Seat	1.4404	1.4404
		316L	316L
7	Disc	1.4122	1.4404
		Hardened stainless steel	316L
8	Guide with bushing	1.0501, 0.7040	1.4404
		Chrome or carbon steel	316L
		1.4104 tenifer	-
		Chrome steel	-
9	Bonnet	0.7043 (Open bonnet 0.7040), 1.0619	1.4408, 1.4404, 1.4571
		Ductile Gr. 60-40-18, SA 216 WCB	SA 351 CF8M, SA 479 316L, 316Ti
12	Spindle	1.4404	1.4404
		316L	316L
14	Split ring	1.4104	1.4404
		Chrome steel	316L
16 / 17	Spring plate	1.0718	1.4404
		Steel	316L
18	Adjusting screw with bushing	1.4104 PTFE	1.4404 PTFE
		Chrome steel PTFE	316L PTFE
19	Lock nut	1.0718	1.4404
		Steel	316L
22	Lift stopper	1.4404	1.4404
		316L	316L
40	Cap H2	1.0718	1.4404
		12L13	316L
54	Spring standard	1.1200, 1.8159, 1.7102	1.4310
		Carbon steel	Stainless steel
	Spring optional	1.4310	-
55	Stud	1.1181	1.4401
		Steel	B8M
56	Nut	1.0501	1.4401
		2H	8M
57	Ball	1.4401	1.4401
		316	316
60	Gasket	Graphite / 1.4401	Graphite / 1.4401
		Graphite / 316	Graphite / 316
61	Ball	1.3541	1.4401
		Hardened stainless steel	316
66	Screw	1.4401	1.4401
		B8M	B8M

Please notice:

- Modifications reserved by LESER.
- LESER can upgrade materials without notice.
- Every part can be replaced by other material acc. to customer specification.

Balanced bellows design

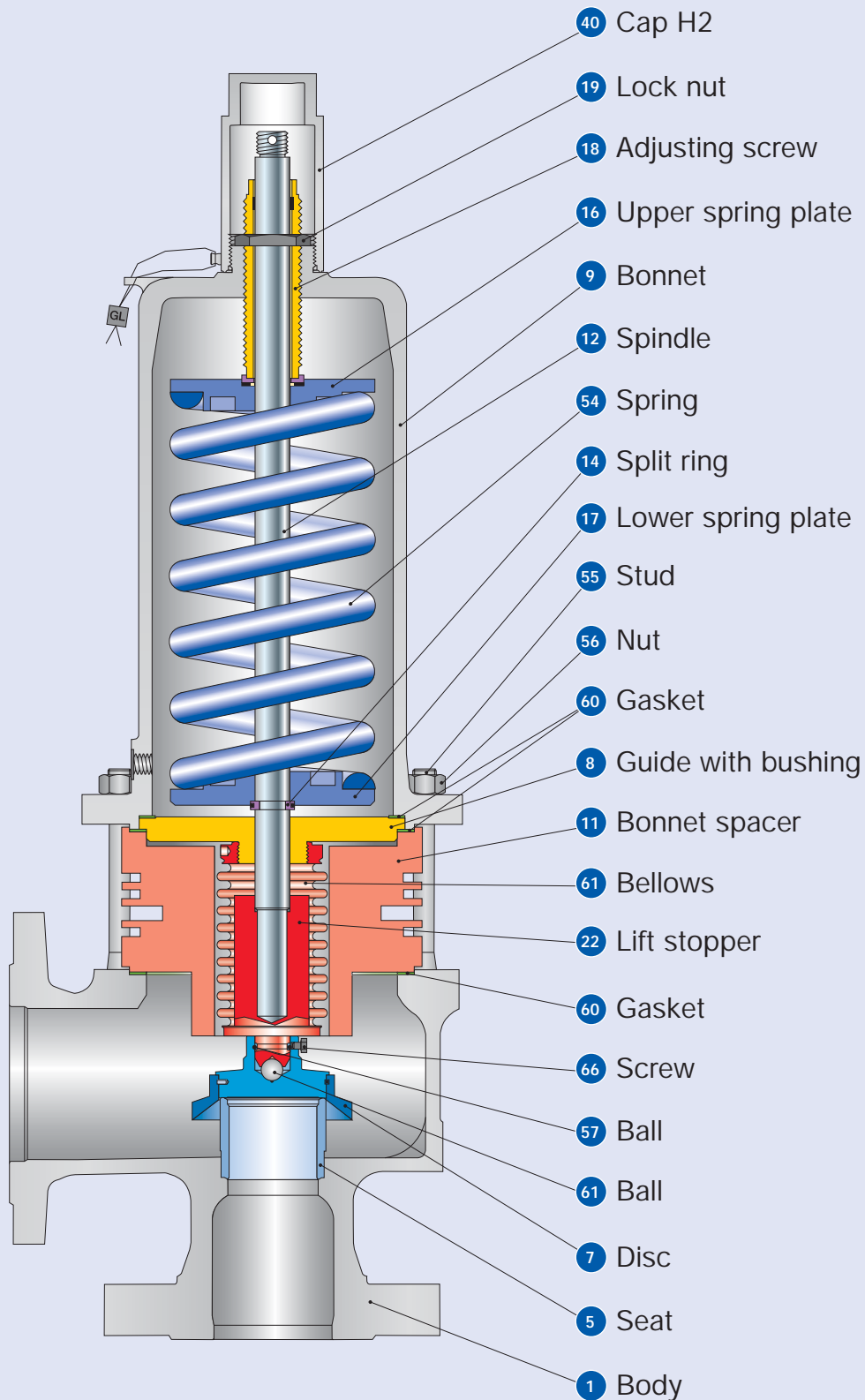

Balanced bellows design

Materials		Type 4552 / 4562	Type 4564
1	Body	1.0619	1.4581
		SA 216 WCB	SA 351 CF10M
5	Seat	1.4404	1.4404
		316L	316L
7	Disc	1.4122	1.4404
		Hardened stainless steel	316L
8	Guide with bushing	1.0501, 0.7040	1.4404
		Chrome or carbon steel	316L
		1.4104 tenifer	-
		Chrome steel	-
9	Bonnet	0.7043 or 1.0619	1.4408, 1.4404, 1.4571
		Ductile Gr. 60-40-18 or SA 216 WCB	SA 351 CF8M, SA 479 316L, 316Ti
11	Bonnet spacer	1.0460	1.4404
		Carbon steel	316L
12	Spindle	1.4404	1.4404
		316L	316L
14	Split ring	1.4104	1.4404
		Chrome steel	316L
15	Bellows	1.4571	1.4571
		316Ti	316Ti
16 / 17	Spring plate	1.0718	1.4404
		Steel	316L
18	Adjusting screw with bushing	1.4104 PTFE	1.4404 PTFE
		Chrome steel PTFE	316L PTFE
19	Lock nut	1.0718	1.4404
		Steel	316L
22	Lift stopper	1.4404	1.4404
		316L	316L
40	Cap H2	1.0718	1.4404
		12L13	316L
54	Spring standard	1.1200, 1.8159, 1.7102	1.4310
		Carbon steel	Stainless steel
55	Stud	1.4310	-
		Stainless steel	-
56	Nut	1.1181	1.4401
		Steel	B8M
57	Ball	1.0501	1.4401
		2H	8M
60	Gasket	1.4401	1.4401
		316	316
61	Ball	Graphite / 1.4401	Graphite / 1.4401
		Graphite / 316	Graphite / 316
66	Screw	1.3541	1.4401
		Hardened stainless steel	316
66	Screw	1.4401	1.4401
		B8M	B8M

Please notice:

- Modifications reserved by LESER.
- LESER can upgrade materials without notice.
- Every part can be replaced by other material acc. to customer specification.