



FREE FLOAT STEAM TRAP

MODEL JH8R-X/JH8R-B

FREE FLOAT STEAM TRAP WITH THERMOSTATIC AIR VENTING

Features

A reliable and durable cast steel steam trap for use on large-size process equipment. JH8R-B is also suitable for high-pressure process equipment.

1. Self-modulating free float provides continuous, smooth, low-velocity condensate discharge as process loads vary.
2. Constant water seal design ensures a steam-tight seal, even under low-load conditions.
3. Only one moving part, the free float, eliminates concentrated valve wear and provides a long maintenance-free service life.
4. **JH8R-X:** Thermostatic capsule (X-element) with “fail open” feature vents air automatically at close-to-steam temperature.
5. **JH8R-B:** Thermostatic bimetal air vent valve vents air automatically for rapid startup.
6. Built-in screen with large surface area ensures extended trouble-free operation.
7. Easy, inline access to internal parts simplifies cleaning and reduces maintenance costs.



Specifications

Model	JH8R-X		JH8R-B	
	Socket Welded	Flanged	Socket Welded	Flanged
Connection	Socket Welded	Flanged	Socket Welded	Flanged
Size (mm)	50, 80, 100		50, 80, 100	
Orifice No.	0.5, 2, 5, 10, 14, 22, 32		0.5, 2, 5, 10, 14, 22, 32, 40, 46	
Maximum Operating Pressure (MPaG) PMO	0.05, 0.2, 0.5, 1.0, 1.4, 2.2, 3.2		0.05, 0.2, 0.5, 1.0, 1.4, 2.2, 3.2, 4.0, 4.6	
Maximum Differential Pressure (MPa) ΔPMX	0.05, 0.2, 0.5, 1.0, 1.4, 2.2, 3.2		0.05, 0.2, 0.5, 1.0, 1.4, 2.2, 3.2, 4.0, 4.6	
Minimum Operating Pressure (MPaG)	0.01		0.01	
Maximum Operating Temperature (°C) TMO	240		425	
Type of Air Vent	X-element (6 °C subcooling)		Bimetal (vents air up to approx. 100 °C)	

PRESSURE SHELL DESIGN CONDITIONS (NOT OPERATING CONDITIONS): Maximum Allowable Pressure (MPaG) PMA: 4.6 1 MPa = 10.197 kg/cm²
 Maximum Allowable Temperature (°C) TMA: 425



To avoid abnormal operation, accidents or serious injury, DO NOT use this product outside of the specification range. Local regulations may restrict the use of this product to below the conditions quoted.

No.	Description	Material	JIS	ASTM/AISI*
①	Body	Cast Steel	—	A216 Gr.WCB
②	Cover	Carbon Steel	—	A105
③ ^F	Float	Stainless Steel	SUS316L	AISI316L
④ ^R	Orifice	—	—	—
⑤ ^{MR}	Orifice Gasket	Soft Iron	SUYP	AISI1010
⑥ ^{MR}	Orifice Cover Gasket	Graphite/Stainless Steel	- /SUS304	- /AISI304
⑦ ^R	Screen	Stainless Steel	SUS430	AISI430
⑧	Screen Holder	Stainless Steel	SUS304	AISI304
⑨	Snap Ring	Stainless Steel	SUS304	AISI304
⑩ ^{MR}	Cover Gasket	Graphite/Stainless Steel	- /SUS304	- /AISI304
⑪	Cover Bolt	Alloy Steel	SNB16	A193 Gr.B16
⑫	Cover Nut	Carbon Steel	S45C	AISH1045
⑬	Outlet Cover	Stainless Steel	SUS420J2	AISI420
⑭	Outlet Cover Bolt	Alloy Steel	SNB16	A193 Gr.B16
⑮	Outlet Cover Nut	Carbon Steel	S45C	AISH1045
⑯ ^{RX}	Air Vent Unit**	—	—	—
⑰ ^{MRX}	Air Vent Unit Gasket	Soft Iron	SUYP	AISI1010
⑱	Air Vent Guide	Stainless Steel	SUS303	AISI303
⑲	Nameplate	Stainless Steel	SUS304	AISI304
⑳ ^{MR}	Screen Holder Retainer	Stainless Steel	SUS304	AISI304
㉑	Eye Bolt	Stainless Steel	SS400	A6
㉒	Flange	Cast Steel	—	A216 Gr.WCB
㉒	Socket***	Carbon Steel	—	A105
㉓ ^{MR}	Drain Plug Gasket	Soft Iron	SUYP	AISH1010
㉔	Drain Plug	Carbon Steel	S25C	AISI1025

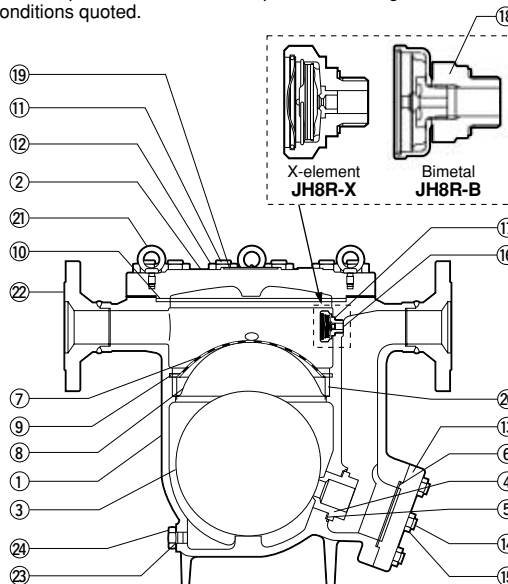

Copyright © TLV

* Equivalent ** Replacement kit for air vent unit: Bimetal (R), X-element (X) *** Shown on reverse
 Replacement kits available: (M) maintenance parts, (R) repair parts, (F) float, (X) X-element unit

Dimensions

● **JH8R-X/JH8R-B** Socket Welded

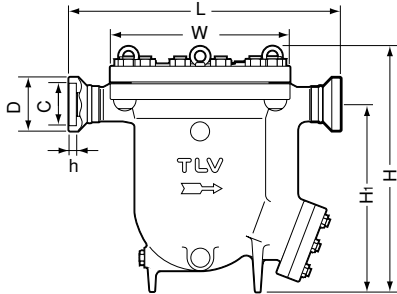

JH8R-X/JH8R-B Socket Welded (mm)

Size	L	H	H ₁	φW	φD	φC	h	Weight (kg)
50	570	524	400	375	77.5	61.1	16	111
80					112	90.0		118
100	610				140	115.3		124

● **JH8R-X/JH8R-B** Flanged

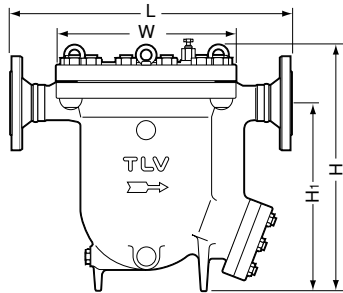

JH8R-X/JH8R-B Flanged (mm)

Size	L			H	H ₁	φW	Weight* (kg)
	ASME Class						
	150RF	300RF	600RF				
50	591	597	616	524	400	375	120
80	588	598	617				130
100	570	596	622				149

Other standards available, but length and weight may vary
* Weight is for class 600 RF

Discharge Capacity

● **JH8R-X**

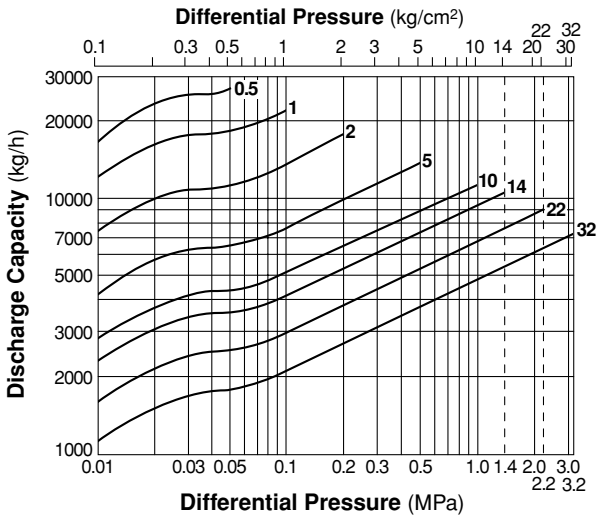

● **JH8R-B**

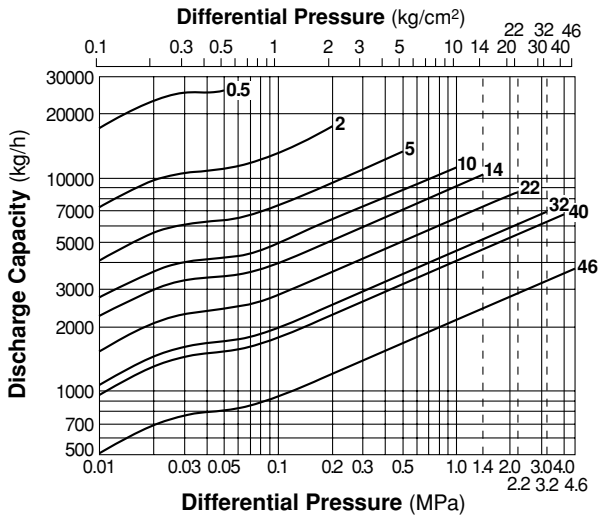

1. Line numbers within the graph are orifice numbers.
2. Differential pressure is the difference between the inlet and outlet pressure of the trap.
3. Capacities are based on continuous discharge of condensate 6°C below saturated steam temperature.
4. Recommended safety factor: at least 1.5.



Do not use traps under conditions that exceed maximum differential pressure, as condensate backup will occur!

Manufacturer

ISO 9001/ISO 14001

TLV CO., LTD.
Kakogawa, Japan

is approved by LRQA Ltd. to ISO 9001/14001

