



BROADY

F L O W C O N T R O L

Type 4000

Pilot Operated Safety Relief Valve



Engineering complete solutions

Call Us on 01482 619600

Visit us at www.broady.valvitalia.com

Type 4000

Pilot Operated Safety Relief Valve

The Broady Type 4000 Flanged Pilot Operated Safety Relief Valve is a high performance product, designed for superior performance in today's ever expanding industries. The Type 4000 is an ASME approved product for both Gas and Liquid applications. The soft seat design of the Type 4000 allows for maximum seat tightness with minimum leakage.

The Type 4000 is available in a range of materials, from Carbon Steel and Stainless Steel, to the more specialised materials required to suit the customer's needs. It is also available with a range of different accessories and can be adapted to suit all different services required. Our R&D department is constantly developing new accessories that aid the user and improve the function of the valve.

Installation and Commissioning

It is most important that the pipeline and valve connections be clean and free from dirt, scale, etc. Avoid bumping or shaking valve to prevent misalignment of trim and damage to flange faces. Fit valve in pipeline with inlet flange down and Adjusting Screw in vertical position above pipeline.

It is also advisable to fit a stop valve on high-pressure side of line. The stop valve should be of full bore type so as not to restrict the flow. Use inlet and outlet pipework as short as possible and of dimensions equal to the valve connections. Uniformly tighten fasteners securing valve connections to pipework. Secure outlet pipework in order to reduce vibration and avoid strain on the outlet. Avoid elbows with small curvature radii on the outlet pipe: for high temperature gas and vapour discharge, use expansion joints. After valve has been installed, make it pop at least twice to allow automatic alignment of trim.

Maintenance

Check at regular intervals for signs of obvious faults. Leakages must be repaired immediately, especially when the medium is poisonous, highly volatile or explosive. Examine annually for signs of defect, damage or deterioration. Give special attention to contact/seating faces. If damaged, these must be re-machined. Springs should be replaced if there is any sign of deterioration. All parts should move freely in their respective guides.

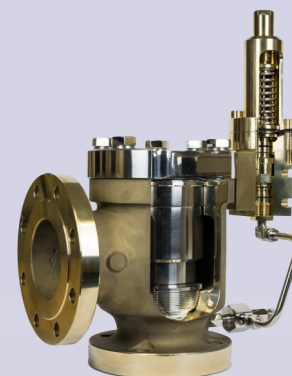

LIMITS & STANDARDS

Minimum Set Pressure: 2 Barg
Maximum Set Pressure: 425 Barg

Design Standards:

- API 520, 526, 527
- ASME VIII

Materials of construction:

- Cast Steels
- Gunmetal
- Aluminium Bronze
- Monel
- Hastelloy
- Inconel

Key Features:

- Direct Acting, Full Lift Safety Valve
- CE Marked to PED Cat IV safety Accessory
- **AMSE Code stamping**
- Gas, Liquid And 2 Phase Applications
- Soft seating area for minimal seat tightness with minimal leakage. Adjustable blowdown of between 3-20%. Site test adaptor and back flow preventer fitted as standard
- Pilot can be modified between Pop action and Modulating depending on the customer's requirements, using the same main valve



Type 4000

Pop/Modulating Action POSRV

57	Spring 1 x 2 to 3 x 4 only
56	Filter
38	Eye Bolt
36	Pick - Up Pipe Connector
35	Plug (Modulating Only)
32	Pilot Block Spacer (Modulating Only)
31	O-Ring
30	O-Ring
29	Washer Spring
28	Socket Head Capscrew
27	O-Ring
26	Plug
25	O-Ring
24	O-Ring
23	O-Ring
22	Blanking Plug
21	Shuttle Valve Seat
20	Shuttle Valve
19	O-Ring
18	CSK Head Screw
17	O-Ring
16	Guide Ring
15	O-Ring
14	O-Ring Retainer
11	Bolt
9	O-Ring
8	Seat Retainer
7	Seat
6	Piston Lid
5	Piston Liner
4	Pick-Up Pipe
2	Cover
1	Body
Item	Title

Items shown in red contained in soft goods kit

6	Socket Headed Blanking Plug
5	O-Ring
4	O-Ring
3	Site Test Adaptor Lid
2	Site Test Adaptor Seat
1	Site Test Adaptor Body
Item	Title

Items shown in red contained in soft goods kit

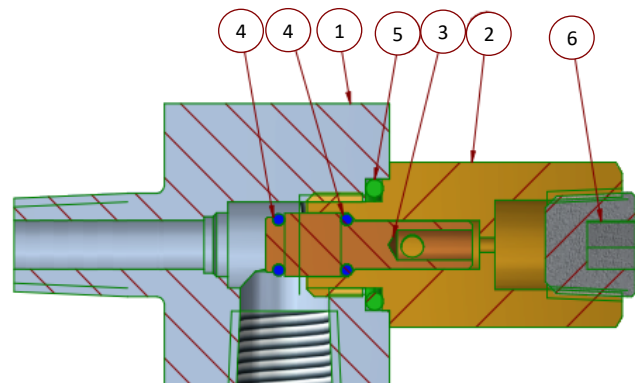
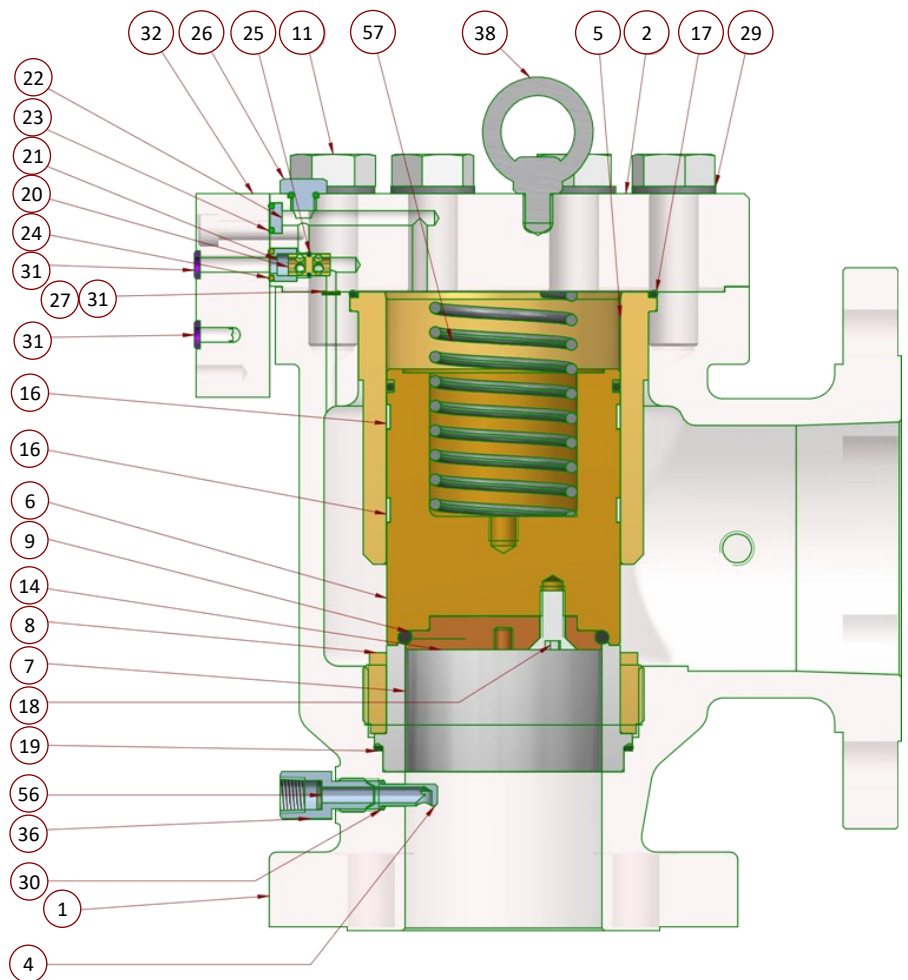

Site Test Adaptor

Type 4000

Modulating Pilot Block

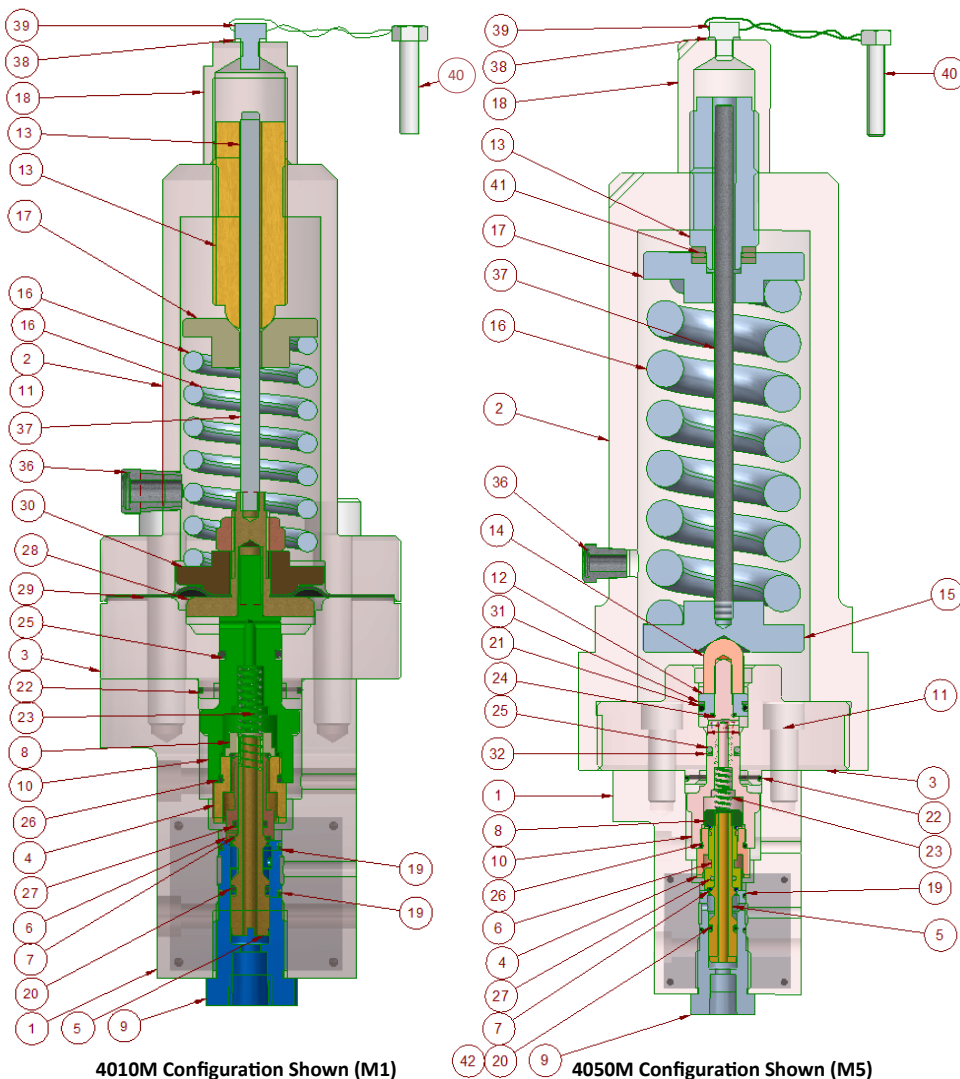

4010M Configuration Shown (M1)

4050M Configuration Shown (M5)

The Type 4000 Pop Action Pilot Valve works by using the operating medium to close the main valve piston lid. The supply pressure on the inlet side of the pilot valve is fed through a pick up pipe inside the inlet branch of the main valve body, through the pilot block assembly into the main valve piston lid chamber. Due to the area of the piston lid chamber being greater than the seating area on the main valve seat, the piston lid remains closed.

When the main piston lid starts to lift it will be proportional to the required flow. As the pressure increases the main piston lid will open further allowing flow to increase up to 110% of the set pressure, where the main piston lid would be fully open allowing maximum flow.

	42	Back Up Ring
	41	Bearing
40	40	Gag Screw (If Req)
39	39	Plug
38	38	Joint
37	37	Spindle
36	36	Vent Plug
	32	Back Up Ring Single Coil
	31	Back Up Ring Single Coil
29		Diaphragm
28		Internal Distance Piece
27	27	O-Ring
26	26	O-Ring
25	25	O-Ring
	24	O-Ring
23	23	Loading Spring Small
22	22	O-Ring
	21	O-Ring
20	20	O-Ring
19	19	O-Ring
18	18	Locking Cover
17	17	Spring Carrier Upper
16	16	Spring Main Pilot
30	15	Spring Carrier Lower
14	14	Nut
13	13	Adjusting Screw
	12	Piston
11	11	Socket Head Capscrew
10	10	Feed Back Piston
9	9	Hex Sleeve
8	8	Spool Upper Seat Collar
7	7	O-Ring
6	6	Spool Sleeve
5	5	Inner Spool
4	4	Inlet Seat
3	3	Distance Piece
2	2	Cover
1	1	Body
Item M1	Item M5	Title

Items shown in red contained in soft goods kit

Please contact the Broady Flow Control sales team who will be happy to assist you in selecting the correct valve for your requirements.

Email: sales@broady.co.uk



Type 4000

POP Action Pilot Block

36	Locking Ring
27	Gag Screw (If Req)
26	Plug
25	Joint
24	Spindle
22	Top Seat Plunger
21	Inverted Insert
20	Inverted Insert Outer Ring
19	Locknut
18	Locking Cover
17	O-Ring
16B	Back Up Ring
16	O-Ring
15B	Back Up Ring
15	O-Ring
14B	Back Up Ring
14	O-Ring
13	Seat Retainer
12	Adjusting Screw
11	Spring Carrier Lower
10	Spring Carrier Upper
9	Spring Pilot Valve
8	Pin Pilot Valve
7	O-Ring
6	Upper Seat Insert
5	Blowdown Piston (Outer)
4	Lower Nozzle Seat
3	Inlet Nozzle
2	Top Seat Sleeve
1	Body
Item	Title

Items shown in red contained in soft goods kit

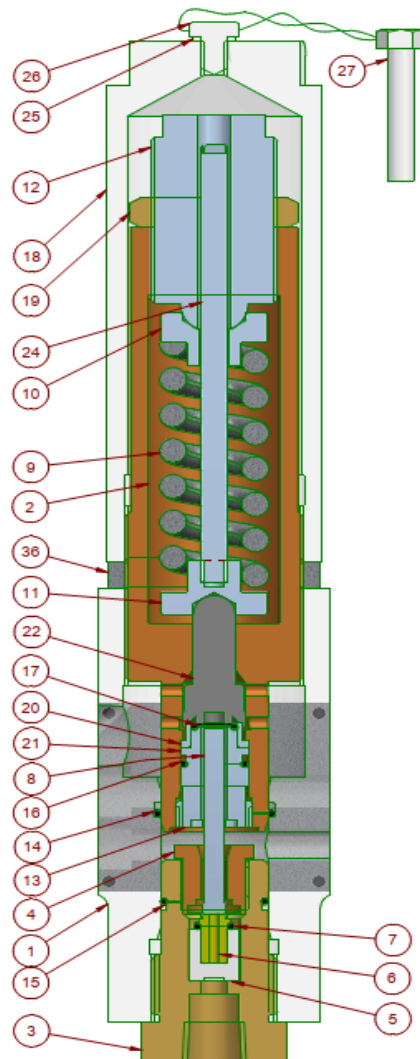

4010P-LP Configuration

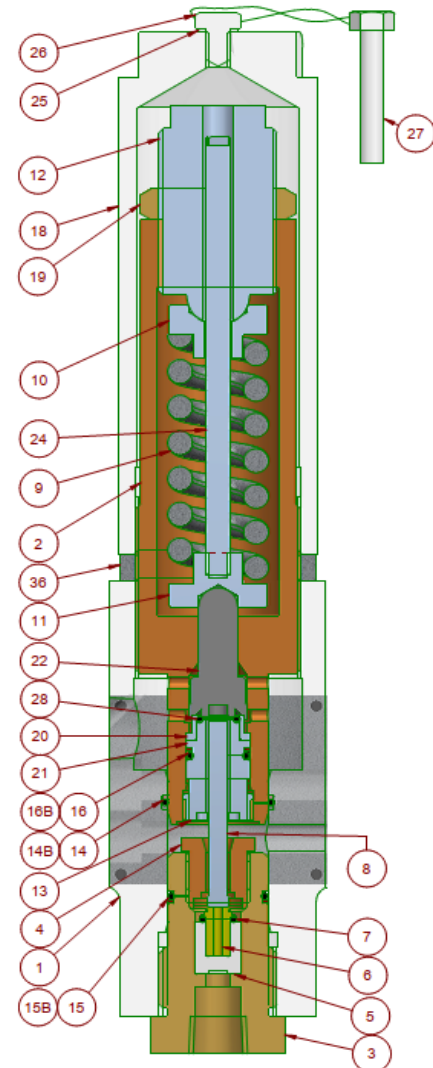

4020P-HP Configuration

HOW TO ORDER

To Enable Broady flow Control to offer the most suitable valve for your service, please provide the following information at the enquiry stage: Set Pressure, Medium, Temperature, Back pressure and Flow.

The Type 4000 Pop Action Pilot Valve works by using the operating medium to close the main valve piston lid.

The supply pressure on the inlet side of the pilot valve is fed through a pick up pipe inside the inlet branch of the main valve body, through the pilot block assembly into the main valve piston lid chamber. Due to the area of the piston lid chamber being greater than the seating area on the main valve seat, the piston lid remains closed. When the valve lifts, it opens very rapidly with a pop action, this allows the piston lid chamber to de-pressurise very rapidly to zero, allowing the piston lid to fully open.

Type 4000 Valve Coding

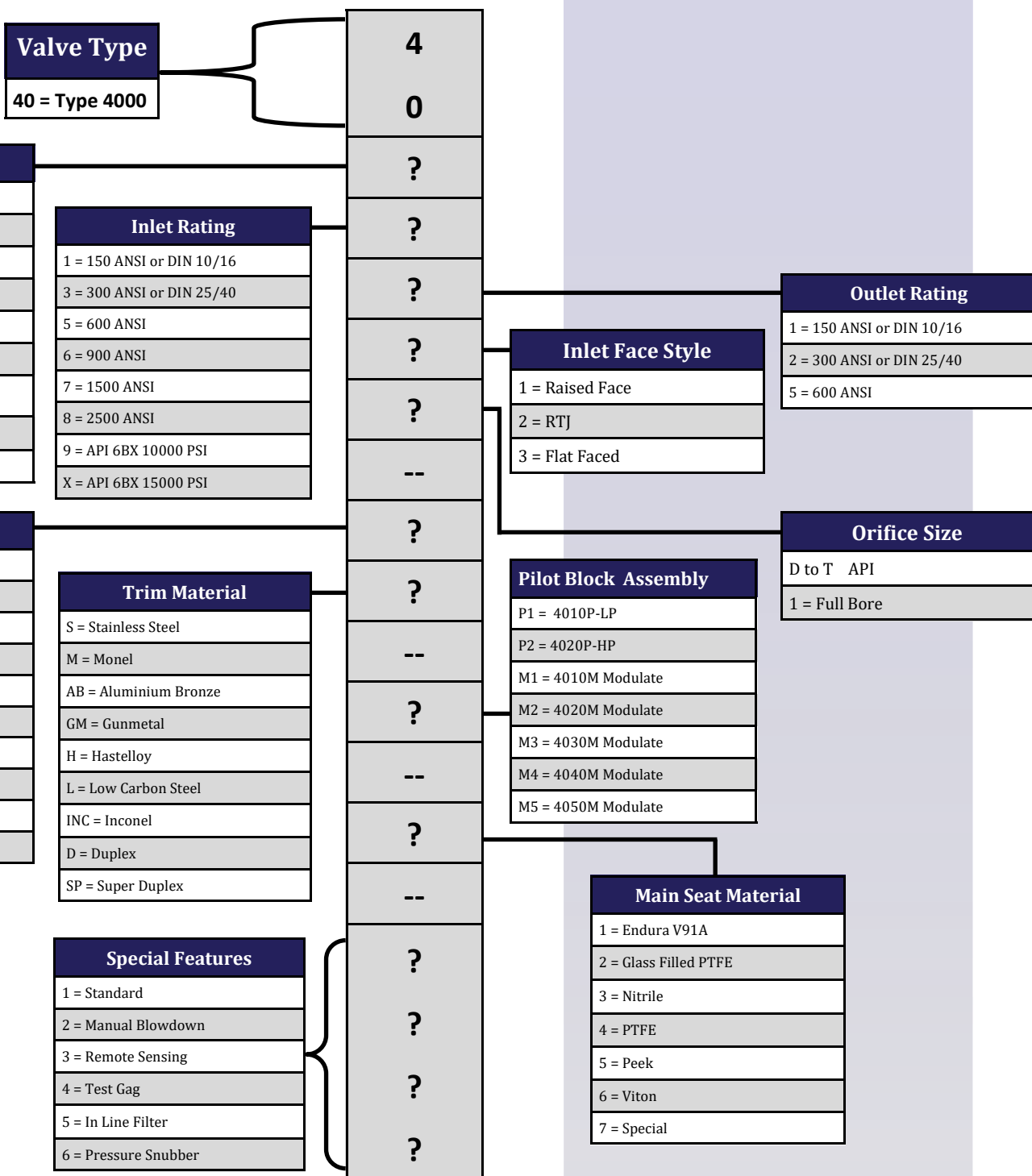



Type 4000

Weights & Dimensions (POP Action)

Type	Inlet x Outlet		Weight	Weight	Inlet	Outlet	A	B	C
	Metric	Imperial	Approx Kg	Approx Kg	Rate	Rate			
			CS/SS	Al Bronze	R/F	R/F	mm	mm	mm
40111 D, E & F	25 x 50	1 x 2	15.5	17.1	150	150	114.3	105	384
40131 D, E & F	25 x 50	1 x 2	16.4	18	300	150	114.3	111.2	390
40151 D, E & F	25 x 50	1 x 2	16.1	17.5	600	150	114.3	111.2	390
40162 D, E & F	25 x 50	1 x 2	27	29.7	900	300	120.7	125.5	418
40172 D, E & F	25 x 50	1 x 2	27	29.7	1500	300	120.7	125.5	418
40182 D, E & F	25 x 50	1 x 2	28	30.8	2500	300	120.7	125.5	418
401½11 D, E & F	40 x 50	1.5 x 2	22	24.2	150	150	121	124	424
401½31 D, E & F	40 x 50	1.5 x 2	23.5	25.9	300	150	121	124	424
401½51 D, E & F	40 x 50	1.5 x 2	23	25.3	600	150	121	124	424
401½62 D, E & F	40 x 50	1.5 x 2	38	41.8	900	300	140	149	450
401½72 D, E & F	40 x 50	1.5 x 2	38	41.8	1500	300	140	149	450
401½82 D, E & F	40 x 50	1.5 x 2	45	49.5	2500	300	140	149	450
40211 G & H	40 x 80	1.5 x 3	23.5	25.9	150	150	123.7	130	418
40231 G & H	40 x 80	1.5 x 3	25.5	28.1	300	150	123.7	130	418
40251 G & H	40 x 80	1.5 x 3	25	27.5	600	150	123.7	130	418
40262 G & H	40 x 80	1.5 x 3	43	47.3	900	300	171.5	162	454
40272 G & H	40 x 80	1.5 x 3	43	47.3	1500	300	171.5	162	454
40282 G & H	40 x 80	1.5 x 3	49	53.9	2500	300	171.5	162	454
40311 G, H & J	50 x 80	2 x 3	30	33	150	150	123.7	136.4	433
40331 G, H & J	50 x 80	2 x 3	30.5	33.6	300	150	123.7	136.4	433
40351 G, H & J	50 x 80	2 x 3	30	33	600	150	123.7	136.4	433
40362 G, H & J	50 x 80	2 x 3	50	55	900	300	171.5	166.6	466
40372 G, H & J	50 x 80	2 x 3	50	55	1500	300	171.5	166.6	466
40382 G, H & J	50 x 80	2 x 3	67	73.7	2500	300	171.5	177.8	486
40411J, K & L	80 x 100	3 x 4	53	58.3	150	150	162	156	489
40431J, K & L	80 x 100	3 x 4	54	60	300	150	162	156	490
40451J, K & L	80 x 100	3 x 4	54	59.4	600	150	162	162	496
40462J, K & L	80 x 100	3 x 4	84	92.4	900	300	180	190.5	514
40472J, K & L	80 x 100	3 x 4	87	95.7	1500	300	180	190.5	514
40511L, M, N & P	100 x 150	4 x 6	80.5	88.6	150	150	209.5	196.8	563
40531L, M, N & P	100 x 150	4 x 6	83.5	91.9	300	150	209.5	196.8	563
40551L, M, N & P	100 x 150	4 x 6	85	93.5	600	150	209.5	196.8	563
40562L, M, N & P	100 x 150	4 x 6	147	161.7	900	300	233.4	250	620
40572L, M, N & P	100 x 150	4 x 6	150	165	1500	300	233.4	247.3	620
40611 Q & R	150 x 200	6 x 8	183.5	201.9	150	150	241.3	239.7	645
40631 Q & R	150 x 200	6 x 8	189	207.9	300	150	241.3	239.7	645
40651 Q & R	150 x 200	6 x 8	204	224.4	600	150	241.3	246.5	654
40652 Q & R	150 x 200	6 x 8	210	231	900	300	265	246.5	654
40711 T	200 x 250	8 x 10	311	342.1	150	150	279.4	276.3	729
40731 T	200 x 250	8 x 10	319	350.9	300	150	279.4	276.3	729
40751 T	200 x 250	8 x 10	345	379.5	600	150	279.4	297	729

A = Centre of Inlet to Outlet Face

B = Centre of Outlet to Inlet Face

C = Height

Type 4000

Weights & Dimensions (Modulating Action)

Type	Inlet x Outlet		Weight	Weight	Inlet	Outlet	A	B	C
	Metric	Imperial	Approx Kg	Approx Kg	Rate	Rate			
			CS/SS	Al Bronze	R/F	R/F	mm	mm	mm
40111 D, E & F	25 x 50	1 x 2	20.5	22.6	150	150	114.3	105	416
40131 D, E & F	25 x 50	1 x 2	21.4	23.5	300	150	114.3	111.2	419
40151 D, E & F	25 x 50	1 x 2	21.1	23.2	600	150	114.3	111.2	419
40162 D, E & F	25 x 50	1 x 2	43	47.3	900	300	120.7	125.5	559
40172 D, E & F	25 x 50	1 x 2	43	47.3	1500	300	120.7	125.5	559
40182 D, E & F	25 x 50	1 x 2	44	48.4	2500	300	120.7	125.5	559
401½11 D, E & F	40 x 50	1.5 x 2	27	29.7	150	150	121	124	453
401½31 D, E & F	40 x 50	1.5 x 2	28.5	31.4	300	150	121	124	453
401½51 D, E & F	40 x 50	1.5 x 2	28	30.8	600	150	121	124	471
401½62 D, E & F	40 x 50	1.5 x 2	54	59.4	900	300	140	149	591
401½72 D, E & F	40 x 50	1.5 x 2	54	59.4	1500	300	140	149	591
401½82 D, E & F	40 x 50	1.5 x 2	60.5	66.6	2500	300	140	149	591
40211 G & H	40 x 80	1.5 x 3	28.5	31.4	150	150	123.7	130	448
40231 G & H	40 x 80	1.5 x 3	30.5	33.6	300	150	123.7	130	448
40251 G & H	40 x 80	1.5 x 3	30	33	600	150	123.7	130	465
40262 G & H	40 x 80	1.5 x 3	59	64.9	900	300	171.5	162	595
40272 G & H	40 x 80	1.5 x 3	59	64.9	1500	300	171.5	162	595
40282 G & H	40 x 80	1.5 x 3	65	71.5	2500	300	171.5	162	595
40311 G, H & J	50 x 80	2 x 3	35	38.5	150	150	123.7	136.4	462
40331 G, H & J	50 x 80	2 x 3	35.5	39.1	300	150	123.7	136.4	462
40351 G, H & J	50 x 80	2 x 3	35	38.5	600	150	123.7	136.4	480
40362 G, H & J	50 x 80	2 x 3	66	72.6	900	300	171.5	166.6	608
40372 G, H & J	50 x 80	2 x 3	66	72.6	1500	300	171.5	166.6	608
40382 G, H & J	50 x 80	2 x 3	83	91.3	2500	300	171.5	177.8	627
40411J, K & L	80 x 100	3 x 4	58	63.8	150	150	162	156	518
40431J, K & L	80 x 100	3 x 4	59.9	65.5	300	150	162	156	519
40451J, K & L	80 x 100	3 x 4	59	64.9	600	150	162	162	525
40462J, K & L	80 x 100	3 x 4	100	110	900	300	180	190.5	655
40472J, K & L	80 x 100	3 x 4	103	113.3	1500	300	180	190.5	655
40511L, M, N & P	100 x 150	4 x 6	85.5	94.1	150	150	209.5	196.8	592
40531L, M, N & P	100 x 150	4 x 6	88.5	97.4	300	150	209.5	196.8	592
40551L, M, N & P	100 x 150	4 x 6	90	99	600	150	209.5	196.8	610
40562L, M, N & P	100 x 150	4 x 6	163	179.3	900	300	233.4	250	761
40572L, M, N & P	100 x 150	4 x 6	166	182.6	1500	300	233.4	247.3	761
40611 Q & R	150 x 200	6 x 8	188.5	207.4	150	150	241.3	239.7	674
40631 Q & R	150 x 200	6 x 8	194	213.4	300	150	241.3	239.7	674
40651 Q & R	150 x 200	6 x 8	209	229.98	600	150	241.3	246.5	701
40652 Q & R	150 x 200	6 x 8	215	236.5	900	300	265	246.5	701
40711 T	200 x 250	8 x 10	316	347.6	150	150	279.4	276.3	758
40731 T	200 x 250	8 x 10	324	356.4	300	150	279.4	276.3	758
40751 T	200 x 250	8 x 10	350	385	600	150	279.4	297	795

A = Centre of Inlet to Outlet Face

B = Centre of Outlet to Inlet Face

C = Height



BROADY

F L O W C O N T R O L

Type 4000

Accessories & Options

Inline Filter

An Inline Filter should be used for any valve considered to be used on dirty service. The pilot block is a high integrity precise design that can become easily clogged and blocked if the service is dirty. The inline filter ensures the Pilot block remains free from such contamination and functions correctly.

Manual Blowdown

This Valve allows opening of the valve without actuation of the pilot valve. Opening of the blowdown valve rapidly depressurises the main valve piston lid chamber, allowing the lid to lift and the valve to discharge.

Remote Sensing

When inlet pressure losses are greater than 3%, remote sensing is required. Connection to the system that is to be protected should be where the pressure is stable. The flow should be minimal so that the sensing is not effected when the main valve is discharging.

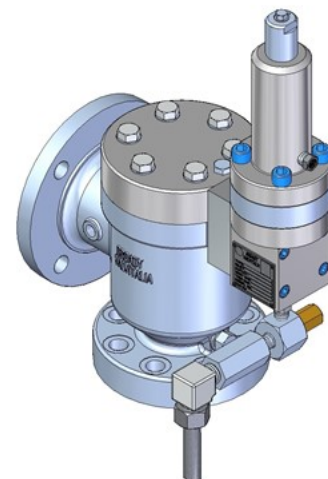
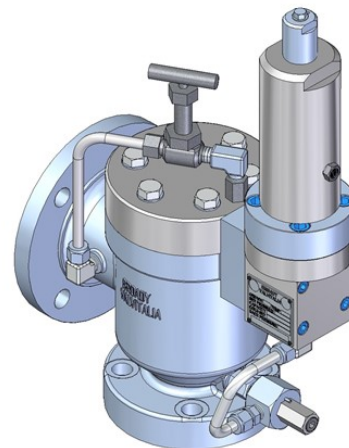
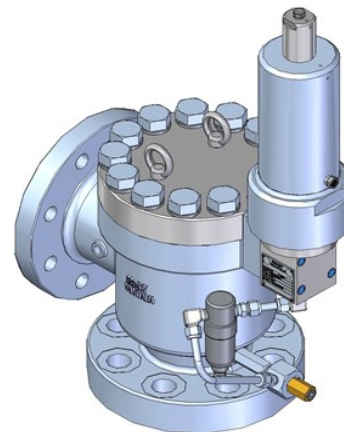

Type 4000

Accessories & Options

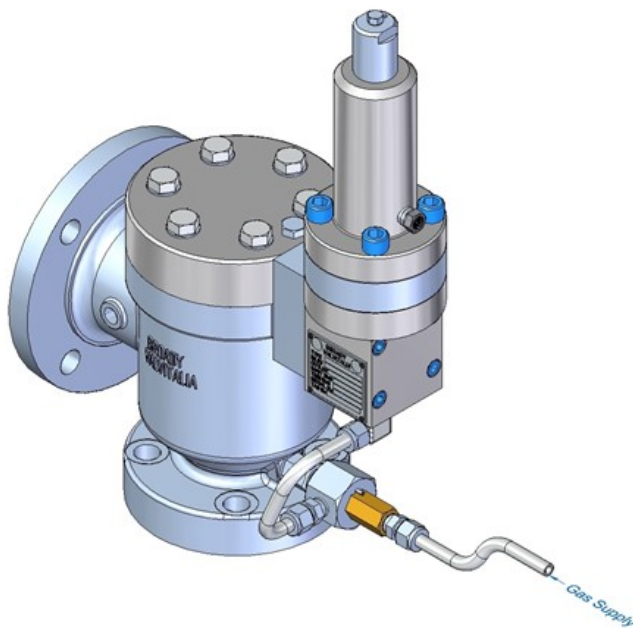
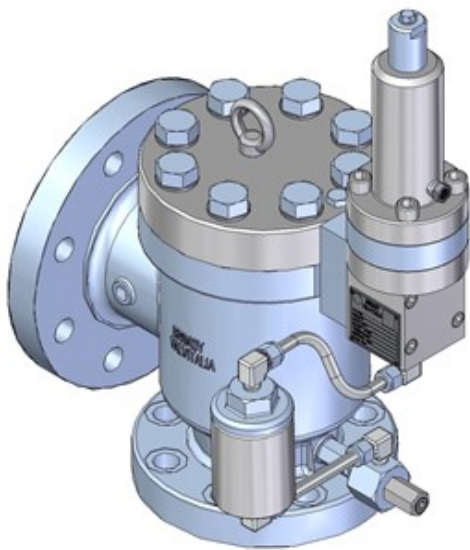

Other accessories are available.

Please contact the Broady sales team for further information.

Surge Snubber

This feature provides extra volume and scatters the fluid path to help ensure a constant pressure supply to the pilot for service that involves pulsations or pressure spikes. Uncontrolled pulsations from a positive displacement compressor or similar equipment may have the effect of opening the pilot prematurely, below set pressure.

Field Test Connector

The Field Test Connector allows the user to verify set pressure while in service without removing the valve. An external pressure source is attached to the Field Test Connector to introduce pressure to the pilot. As the pilot discharges the main valve will open. The benefit of the FTC is the valve can be full check for functionality without having to over pressure the inlet.



BROADY

F L O W C O N T R O L

Broady Quality



Broady Flow Control Limited, over its many years of trading, has developed into a highly efficient and customer focused organisation, well placed to satisfy the ever changing requirements of the industry. Renowned for innovation, flexibility and integrity.



Broady has a well established and robust quality management system which supports order processing and manufacturing, ensuring the highest standards are maintained at all times.

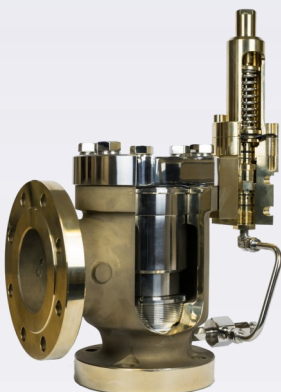

The dedicated management team is supported by a highly skilled and dedicated workforce trained in all engineering disciplines. The future of Broady is assured by the policy of employment and training of young dynamic apprentices who are fully involved in the development and implementation of the quality management system.

At the heart of Broady's philosophy is the desire to strive for continual improvement and complete customer satisfaction through the process of internal and external audits designed to ensure a "right first time" environment.

Broady Flow Control Limited is committed to maintaining and continually improving the quality of the products and services offered to all its customers

Valves from the Broady Product Range



3500 Series Pressure Safety Valves



Fire Fighting (Hydrant Valves)



Type 3600, 2600, 180 & 180-S
Safety Valves



Sustaining Valves
(Type A, Type D, Type 8, Type 9)



Reducing Valves (A, AB, C, D, B2)

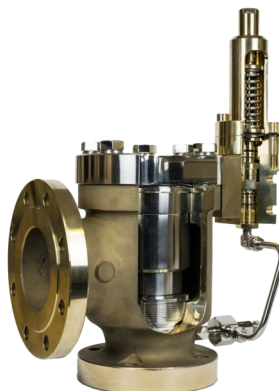

Type 4000 Pilot Operated Safety Relief Valve

Please contact the
Broady Flow Control
Sales department for
more information on
our extensive product
range on +44 (0)1482
619600 or via
sales@broady.co.uk



BROADY

F L O W C O N T R O L



Engineering complete solutions

Broady Flow Control Limited

English Street
Kingston Upon Hull
East Yorkshire
HU32DU

Telephone: +44 (0)1482 619600

Facsimile: +44 (0)1482 619700

Email: sales@broady.co.uk

Website: www.broady.valvitalia.com

Website: www.valvitalia.com



The information, specifications and technical data contained in this guide are subject to change without notice. The user should verify all technical data and specifications prior to use.

Broady Flow control does not warrant that the material and information contained herein is current and assumed no responsibility for the use or misuse of any such material and information by the user.

WARNING: The entire contents of the brochure are subject to the laws of copyright and intellectual property rights. Any infringement will be rigorously pursued.

Call Us on 01482 619600

Visit us at www.broady.valvitalia.com