

10K CAST BRONZE BALL VALVES, WITH ELECTRIC ACTUATOR KELMO

KITZ Fig: EA200-TE

Sizes: 3/8-2inch(10-50mm)
REDUCED BORE, SCREWED ENDS.

Standards

- . End to End: KITZ STANDARD
 - . End Connection: JIS B0203 (7)
 - . Wall Thickness: KITZ STANDARD
- Test Standard
- . KITZ STANDARD

Dimensions

SIZE (inch/mm)	L	L1	H	D1	Kg
3/8 10	46.0	22.0	104.0	0.0	0.00
1/2 15	65.0	32.5	109.5	0.0	0.00
3/4 20	68.0	34.0	113.5	0.0	0.00
1 25	79.0	39.5	117.5	0.0	0.00
1 1/4 32	86.0	43.0	128.5	0.0	0.00
1 1/2 40	96.0	48.0	142.5	0.0	0.00
2 50	109.0	54.5	148.5	0.0	0.00

Material List

NAME OF PART	MATERIAL	SPECIFICATION
BODY	CAST BRONZE	CAC406
BODY CAP	FORGED BRASS	C3771BE
STEM	HIGH TENSION BRASS	C6782BD
BALL	SPECIAL BRASS	

Specifications

10K CAST BRONZE BALL VALVES, WITH ELECTRIC ACTUATOR KELMO, REDUCED BORE, SCREWED ENDS.

End to End : KITZ STANDARD, End Connection : JIS B0203 (7), Wall Thickness : KITZ STANDARD, Test Standard : KITZ STANDARD, Sizes : 3/8-2inch(10-50mm), BODY MATERIAL : CAST BRONZE, BODY CAP MATERIAL : FORGED BRASS, STEM MATERIAL : HIGH TENSION BRASS, BALL MATERIAL : SPECIAL BRASS, KITZ Fig : EA200-TE

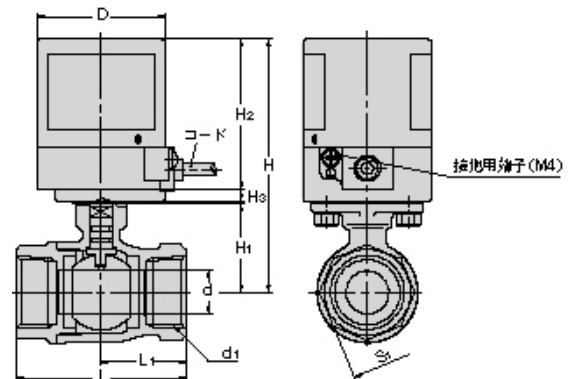

For more details, please refer to the drawing.

Pressure-temperature ratings and other performance data published in this catalog have been developed from our design calculation, in-house testing, field reports provided by our customers and/or published official standards or specifications. They are good only to cover typical applications as a general guideline to users of KITZ products introduced in this catalog. For any specific application, users are kindly requested to contact KITZ Corporation for technical advice, or to carry out their own study and evaluation for proving suitability of these products to such an application. Failure to follow this request could result in property damage and/or personal injury, for which we shall not be liable. Read instruction manual carefully before use.

KITZ

KITZ CORPORATION 1-10-1 Nakase, Mihama-ku, Chiba 261-8577, Japan
© KITZ Corporation. All Right Reserved.

ISO 9001
CERTIFIED
Since 1989