

**MODEL****EB**

## BI-DIRECTIONAL KNIFE GATE VALVE

The EB model knife gate is a bi-directional valve designed for general industrial service applications. The design of the body and seat assures non-clogging shut off on suspended solids in industries such as:

- Wastewater treatment plants
- Food and Beverage
- Chemical plants
- Sludge Handling and storm tanks
- Agriculture
- Biogas plants

**Sizes:** DN 50 to DN 1200 (larger diameters on request)

**Working pressure:**

DN 50 to DN 250	10 kg/cm <sup>2</sup>
DN 300 to DN 400	6 kg/cm <sup>2</sup>
DN 450	5 kg/cm <sup>2</sup>
DN 500 to DN 600	4 kg/cm <sup>2</sup>
DN 700 to DN 1200	2 kg/cm <sup>2</sup>

**Standard flange connection:**

DIN PN 10  
Other flange connections available on request

**Directives:**

2006/42/CE (MACHINES)  
97/23/CE (PED) Fluid: Group 1(b), 2 (Cat. I, mod. A)  
94/9/CE (ATEX)



Face to face dimensions acc. to EN558-1 serie 20 (replaces K1 DIN3202) up to DN500, standard Orbinox for DN600 and above

All valves are tested prior to shipping in accordance with the standard developed by the Quality Control Department at ORBINOX.

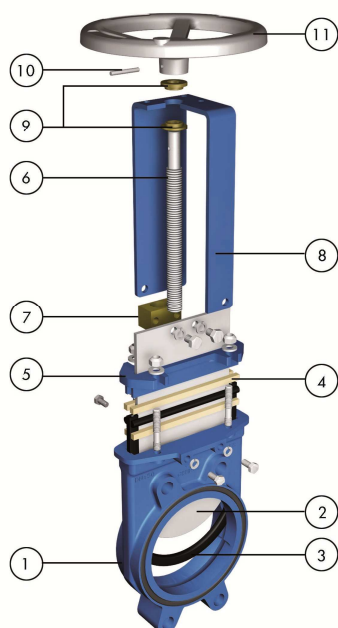

### STANDARD PARTS LIST

Part:	Cast Iron:
1- Body	GJL250 (GG25)
2- Gate	AISI 304
3- Seat	EPDM / Nitrile
4- Packing	PTFE Impreg. Synth. Fibre (ST)+O-ring
5- Gland Follower	GJS400 (GGG40)
6- Stem	AISI 430
7- Stem Nut	Brass
8- Yoke	Carbon Steel - Epoxy Coated
9- Bushing	Brass
10- Spring Pin	AISI 420 (ISO 8752)
11- Handwheel	DN <sub>≤</sub> 310: Aluminium (AlSi12); DN <sub>≥</sub> 410 GJS400 (GGG40)

## DESIGN FEATURES

### BODY:

Wafer style cast monoblock design, internally machined up to DN 500, with reinforced ribs in larger diameters for extra body strength. Special design that includes a new manufacturing process, the machining of the body inside, allowing for more control in the different dimensions tolerances. This machining results in a perfect adjustment of the body with the gate and the seal, reducing the required torque to maintain the tightness and avoiding any build-up of solids that could prevent the valve from closing. The valve design allows an end-of-line installation from DN50 to DN300. The valve design changes from DN 600 and above to a two-part bolted body, also internally machined. Full port design in all cases for greater flow capacity and minimal pressure drop. The gate is guided on the whole stroke to ensure bi-directional shutoff. Standard EPDM O-ring on both valve flange connections for sealing.

### GATE:

Stainless steel gate, as standard. Gate is polished on both sides for a greater seal between the gate with both packing and seat. Gate is fully guided in the body allowing for bi-directional service.

### PACKING:

Standard PTFE impregnated synthetic fibre (ST) with EPDM O-ring, with an easy access packing gland ensuring a tight seal. Long-life braided packing is available in a wide range of materials.

### NON RISING STEM:

The standard stainless steel stem offers a high and long corrosion resistant life.

### ACTUATORS:

All actuators supplied by ORBINOX are interchangeable, and supplied with an standard mounting kit for installation purposes on site.

### YOKE or ACTUATOR SUPPORT:

Made of EPOXY coated steel (stainless steel available on request). Compact design makes it extremely robust even under the most severe conditions.

### EPOXY COATING:

The epoxy coating on all ORBINOX cast iron and carbon steel valve bodies and components is electrostatically applied making the valves to be corrosion resistant with a high quality finished surface. The ORBINOX standard colour is RAL-5015 blue.

### GATE SAFETY PROTECTION:

ORBINOX automated valves are provided with gate guards in accordance with EU Safety Standards. The design feature prevents any objects from being caught accidentally while the gate is moving.

### OTHER MATERIALS:

On request, following materials can be also supplied:

#### Body:

Ductile Iron (GGG-40)  
CF8M on some sizes

#### Gate:

AISI 316 or 316Ti

#### Stem:

AISI 316 or 316 Ti



## ACTUATOR TYPES

### MANUAL:

Handwheel (non-rising stem)  
 Handwheel (rising stem)  
 Chainwheel  
 Lever  
 Bevel Gear  
 Others (square nut...)

### AUTOMATIC:

Electric (rising & non-rising stem)  
 Pneumatic (single & double-acting)  
 Hydraulic

All actuators supplied by ORBINOX are interchangeable.

## FAIL SAFE SYSTEMS

Used on pneumatic actuated valves

### SINGLE ACTING (SPRING RETURN)

- Available from DN 50 to DN 200
- Supply pressure: min. 5 kg/cm<sup>2</sup> - max. 10 kg/cm<sup>2</sup>
- Options:
  - Fail open
  - Fail closed

### SINGLE ACTING (VOLUME TANK)

- Available for all valve sizes
- Standard for valve sizes DN>200mm
- Options:
  - Pneumatic Failsafe

## ACCESSORIES

Mechanical stops  
 Locking device  
 Manual override  
 Solenoid valves  
 Positioners  
 Limit switches  
 Proximity switches  
 Floor stands  
 Stem extensions

Wide range of valve extensions available

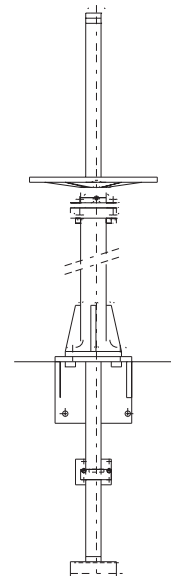

*For further information about fail safe systems and valve extensions, please see EX catalogue.*

For more detailed information, please contact our Technical Department.

## TEMPERATURE CHART

### SEAT / SEALS

Material	Max.Temp.(°C)	Applications
EPDM (E)	120	Acid and non mineral oils
Nitrile (N)	120	Resistance to petroleum products
On request:		
Viton (V)	200	Chemical service / High temp.

More details and other materials on request.

### PACKING

Material	Max.Temp.(°C)	pH
PTFE impregn.synth fibre (ST)	240	2-13
Dynapack (DP)	270	2-14
Dry cotton (AS)	50	6-8
Braided PTFE (TH)	260	0 - 14

NOTE: All types include an elastomere O-ring (same material as seal), excluding TH. Standard packing: ST

## SEAT TYPES

### RESILIENT SEAT

This is the standard seat. The joint is seated on the body, fitted with a metallic core, in contact with the gate all over its perimeter. This layout provides an adequate watertightness and seamless liquid flow on both ways, avoiding at the same time any build-up of solids that would prevent the valve from closing. The seal is protected by the body itself.

- DN50-500: Moulded seal with an internal steel core
- DN ≥ 600: Extruded seal with an internal steel wire

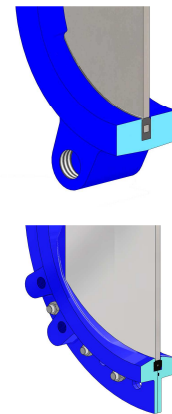

## ATEX



Please contact our ORBINOX representative for info and availability. Some considerations:

- Hand operated EB valves have been subjected to an ignition risk assessment according to DIN EN 13463: 1-5 and they are out the scope of application of ATEX Directive. Therefore hand operated valves are suitable for ALL ATEX zones.
- Electrical, pneumatical and hydraulically operated valves must be subjected to a conformity assessment of their own and also of the whole unit valve-actuator to get EC Type Approval to Directive 94/9.

## HANDWHEEL (non-rising stem)

- Standard manual actuator
- Consists of:
  - Handwheel
    - DN 50-300: Aluminium
    - DN  $\geq$  350: GJS400 (GGG40)
  - Stem
  - Yoke bushing
  - Stem nut fixed to the gate
- Available from DN 50 to DN 1000
- Options (on request):
  - Locking Device
  - Extension
  - Square Nut Drive

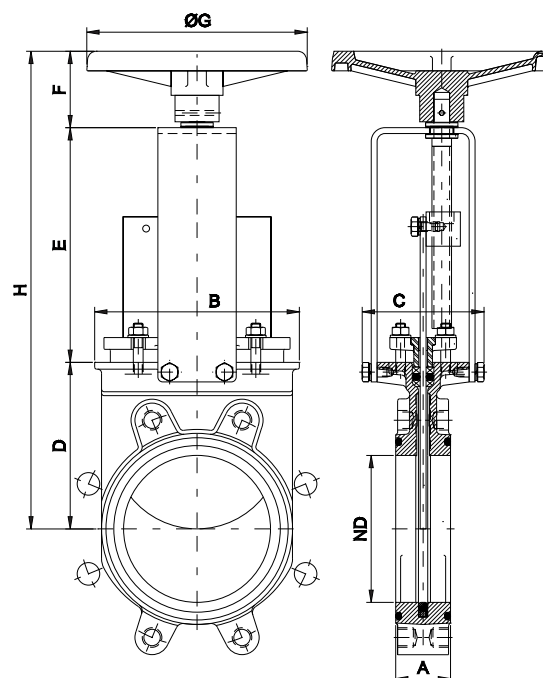

DN	A	B	C	D	E	F	ØG	H	Weight (kg.)
50	43	113	124	105	132	78	225	315	8
65	46	128	124	115	149	78	225	342	9
80	46	143	124	124	165	78	225	367	10
100	52	162	124	140	190	78	225	408	12
125	56	181	124	150	214	78	225	442	15
150	56	209	124	170	240	78	225	488	17
200	60	263	142	205	305	92	310	602	30
250	68	315	142	250	360	92	310	702	42
300	78	370	142	290	410	92	310	792	60
350	78	420	197	325	487	110	410	922	90
400	102	478	197	360	537	110	410	1007	140
450	114	530	201	410	589	111	550	1110	185
500	127	584	201	450	649	111	550	1210	204
600	110	762	201	510	800	111	550	1434	230
700	110	890	398	601	979	147	800	1727	380
800	110	1012	320	695	1076	147	800	1918	550
900	110	1112	320	795	1115	147	800	2057	680
1000	110	1240	320	875	1220	147	800	2247	800

A: EN558-1 serie 20 up to DN500

## CHAINWHEEL (non-rising stem)

- Recommended for elevated installations.
- Consists of:
  - Chainwheel: Epoxy coated Cast Iron
  - Stem
  - Yoke bushings
  - Stem nut
- Available from DN 50 to DN 600
- Options (on request):
  - Locking Device
  - Extensions and floor stands

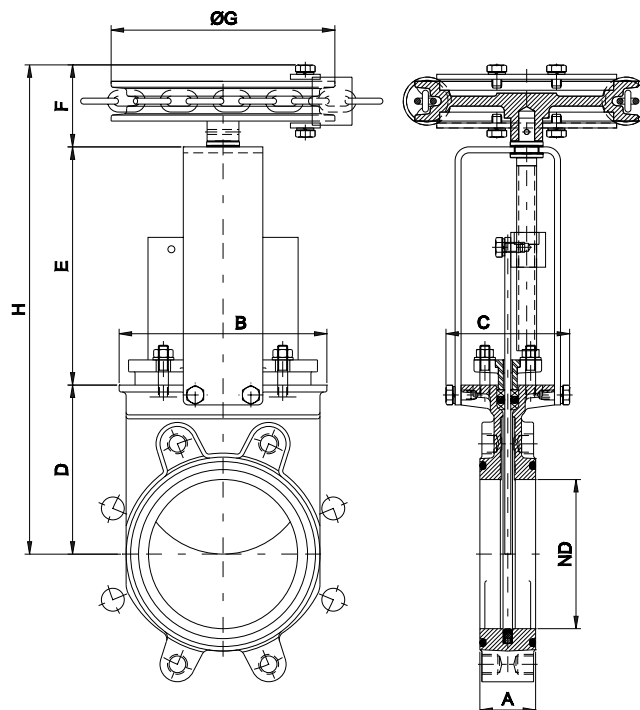

DN	A	B	C	D	E	F	ØG	H
50	43	113	124	105	132	82	225	319
65	46	128	124	115	149	82	225	346
80	46	143	124	124	165	82	225	371
100	52	162	124	140	190	82	225	412
125	56	181	124	150	214	82	225	446
150	56	209	124	170	240	82	225	492
200	60	263	142	205	305	88	300	598
250	68	315	142	250	360	88	300	698
300	78	370	142	290	410	88	300	788
350	78	420	197	325	487	98	454	910
400	102	478	197	360	537	98	454	995
450	114	530	201	410	589	98	454	1097
500	127	584	201	450	649	98	454	1197
600	110	762	201	510	800	98	454	1408

A: EN558-1 serie 20 up to DN500

**LEVER**

- Recommended for quick opening and closing.
- Consists of:
  - Lever
  - Stem
  - Yoke sleeve
  - Lever lock
- Available from DN 50 to DN 150

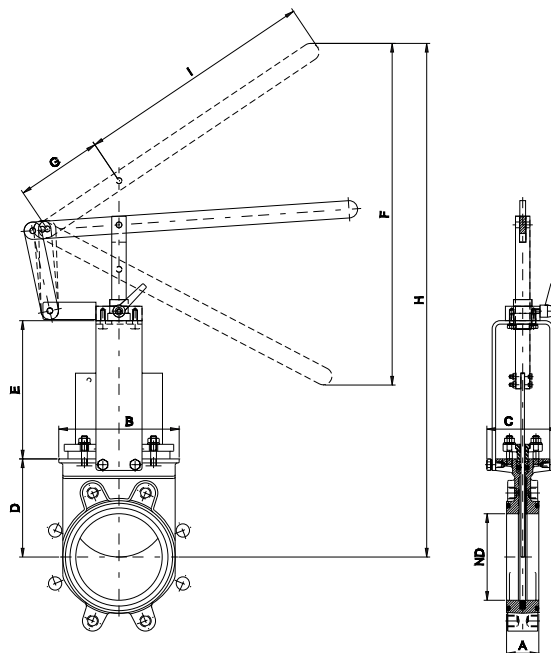

DN	A	B	C	D	E	F	G	H	I
50	43	113	124	105	132	242	150	410	315
65	46	128	124	115	149	245	150	437	315
80	46	143	124	124	165	287	150	510	315
100	52	162	124	140	190	415	150	633	415
125	56	181	124	150	214	503	150	755	415
150	56	209	124	170	240	592	150	890	415

A: EN558-1 serie 20 up to DN500

**GEAR (non-rising stem)**

- Recommended for valves larger than DN 350 and working pressures greater than 3,5 kg/cm<sup>2</sup>

- Consists of:

- Stem
- Yoke
- Bevel Gear Actuator with Handwheel (Standard Ratio 4:1)

- Available from DN 200 to DN 1200

- Options:

- Locking device
- Extension and floor stand
- Chainwheel
- Rising stem

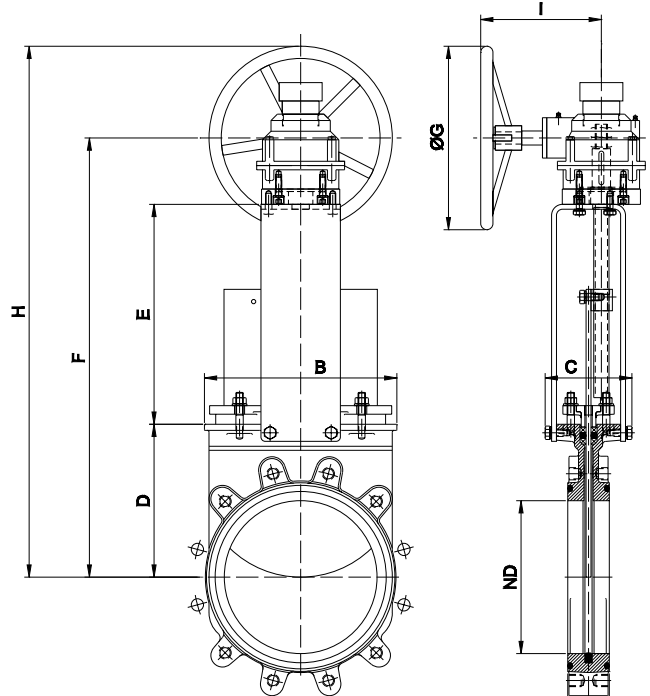

DN	A	B	C	D	E	F	ØG	H	I
200	60	263	142	205	305	580	300	730	200
250	68	315	142	250	360	680	300	830	200
300	78	370	142	290	410	770	300	920	200
350	78	420	197	325	490	890	450	1115	262
400	102	478	197	360	540	975	450	1200	262
450	114	530	201	410	592	1077	450	1305	262
500	127	584	201	450	652	1177	450	1405	262
600	110	762	201	510	755	1340	450	1565	262
700	110	890	398	610	900	1622	450	1847	308
800	110	1012	320	700	971	1782	450	2007	308
900	110	1112	320	785	1092	1990	450	2215	308
1000	110	1240	320	1120	1205	2442	450	2607	308
1200	150	1470	450	1340	1480	2996	650	3321	288

A: EN558-1 serie 20 up to DN500



**PNEUMATIC CYLINDER**

- The standard pneumatic actuator (double acting on-off cylinder) consists of:
  - DN $\leq$ 250: Aluminum barrels
  - DN $\geq$ 300: Composite barrels
  - Aluminum end covers
  - Stainless Steel (AISI 304) piston rod
  - Nitrile coated steel piston
- Available from DN 50 to DN 800
- Supply Pressure: minimum 3.5 kg/cm<sup>2</sup> - maximum 10 kg/cm<sup>2</sup>. Actuator designed with 6 kg/cm<sup>2</sup> air supply
- For valves installed in a horizontal position, we recommend U-type support plates and/or actuator support
- Options (on request):
  - Hard anodized barrel and covers
  - Stainless Steel barrel and covers
  - Over/Undersized cylinder
  - Manual override
  - Fail safe system
  - Limit switches
- Instrumentation (on request):
  - Positioners
  - Solenoid valves
  - Flow regulators
  - Air preparation units

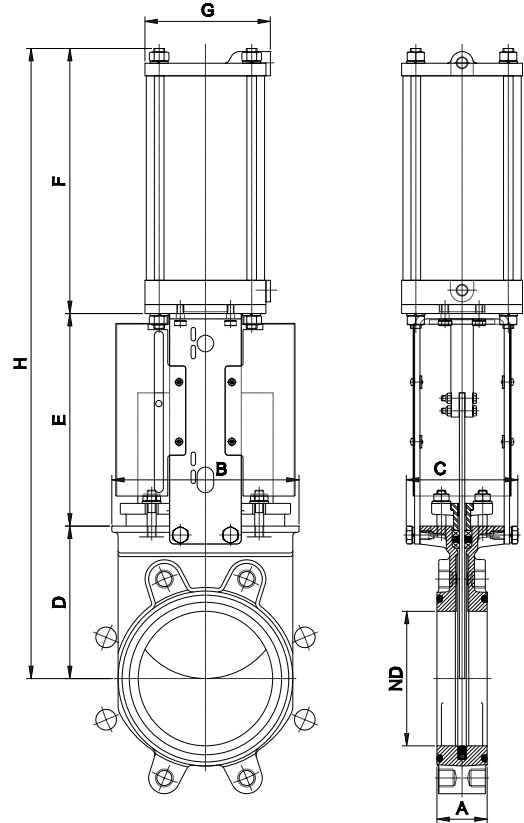

DN	A	B	C	D	E	F	G	H	Weight (kg.)	Standard Cyl	Connect.
50	43	113	124	105	129	178	115	412	9	C100/62	1/4" G
65	46	128	124	115	146	193	115	454	10	C100/77	1/4" G
80	46	143	124	124	162	211	115	497	11	C100/95	1/4" G
100	52	162	124	140	187	231	115	558	13.5	C100/115	1/4" G
125	56	181	124	150	211	271	140	632	19	C125/143	1/4" G
150	56	209	124	170	237	296	140	703	22	C125/168	1/4" G
200	60	263	142	205	309	358	175	872	47	C160/220	1/4" G
250	68	315	142	250	364	428	220	1042	58	C200/270	3/8" G
300	78	370	142	290	414	478	220	1182	84	C200/320	3/8" G
350	78	420	197	325	500	549	277	1374	130	C250/375	3/8" G
400	102	478	197	360	550	599	277	1509	181	C250/425	3/8" G
450	114	530	201	410	598	680	382	1688	235	C300/475	1/2" G
500	127	584	201	450	658	730	382	1838	302	C300/525	1/2" G
600	110	762	201	510	758	830	382	2098	315	C300/625	1/2" G
700	110	890	380	601	875	985	444	2461	480	C350/730	3/4" G
800	110	1012	320	695	974	1035	444	2704	585	C350/830	3/4" G

A: EN558-1 serie 20 up to DN500

**ELECTRIC ACTUATOR (rising stem)**

- Consists of:
  - Electric motor
  - Motor support yoke flange acc. to ISO 5210 / DIN 3338
- The standard electric motor is equipped with:
  - Manual emergency operation
  - Limit switches (open/closed)
  - Torque switches
- Available from DN 50 to DN 1200
- For valves installed in a horizontal position, we recommend U-type support plates and/or actuator support
- Wide ranges of types and brands available to meet customer's needs

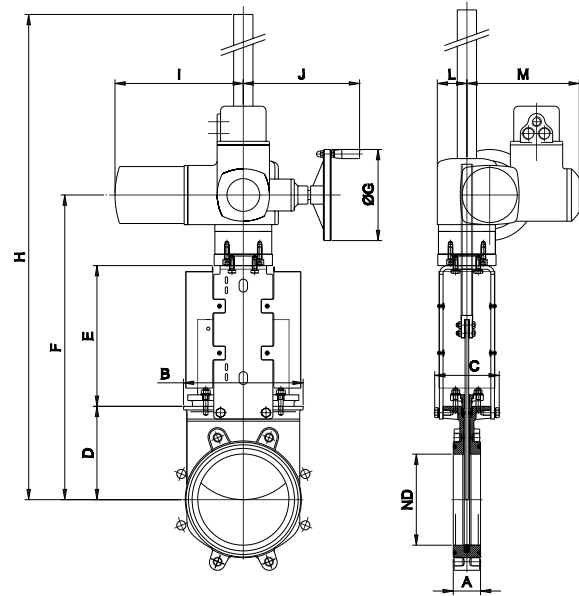

DN	A	B	C	D	E	F	ØG	H	I	J	L	M	StemØxpitch	Torque (Nm)
50	43	113	124	105	129	377	160	532	265	249	62	238	20 x 4	10
65	46	128	124	115	146	404	160	600	265	249	62	238	20 x 4	10
80	46	143	124	124	162	429	160	674	265	249	62	238	20 x 4	10
100	52	162	124	140	187	470	160	665	265	249	62	238	20 x 4	10
125	56	181	124	150	211	504	160	700	265	249	62	238	20 x 4	15
150	56	209	124	170	237	550	160	1120	265	249	62	238	20 x 4	20
200	60	263	142	205	309	657	160	1237	265	249	62	238	24 x 5	30
250	68	315	142	250	364	757	160	1337	265	249	62	238	24 x 5	45
300	78	370	142	290	414	847	160	1427	265	249	62	238	24 x 5	40
350	78	420	197	325	500	955	200	1535	283	254	65	248	36 x 6	70
400	102	478	197	360	550	1040	200	1620	283	254	65	248	36 x 6	90
450	114	530	270	410	598	1129	200	1724	283	254	65	248	36 x 6	110
500	127	684	270	450	658	1238	200	1833	283	254	65	248	36 x 6	95
600	110	762	270	503	758	1376	315	2093	389	336	91	286	36 x 6	140
700	110	890	380	610	875	1660	315	2800	389	336	91	285	40 x 7	120
800	110	1012	320	695	979	1849	315	2989	389	336	91	286	50 x 8	180
900	110	1112	320	795	1115	2085	315	3225	389	336	91	286	50 x 8	220
1000	110	1240	320	875	1225	2275	400	3430	389	339	91	286	50 x 8	300
1200	150	1470	450	1340	1455	3005	400	4430	389	339	91	286	60 x 9	480

A: EN558-1 serie 20 up to DN500

Maximum pressure torque in clean water at room temperature

**ELECTRIC ACTUATOR (non-rising stem)**

- Consists of:
  - Electric motor
  - Motor support yoke flange acc. to ISO 5210 / DIN 3338
- The standard electric motor is equipped with:
  - Manual emergency operation
  - Limit switches (open/closed)
  - Torque switches
- Available from DN 50 to DN 1200
- For valves installed in a horizontal position, we recommend U-type support plates and/or actuator support
- Wide range of types and brands available to meet customer's needs

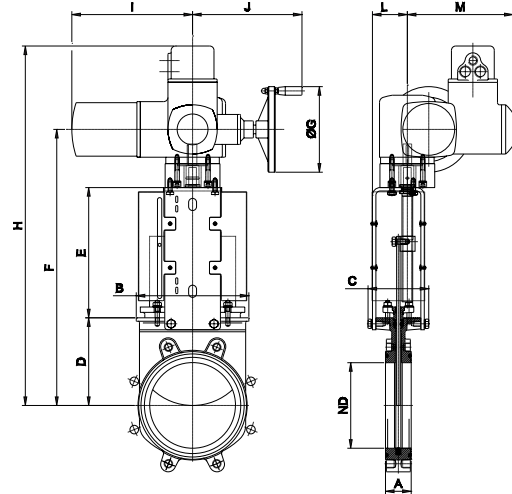



DN	A	B	C	D	E	F	ØG	H	I	J	L	M	StemØxpitch	Torque(Nm)
50	43	113	124	105	132	370	160	545	265	249	72	238	20 x 3	10
65	46	128	124	115	149	397	160	572	265	249	72	238	20 x 3	10
80	46	143	124	124	165	422	160	597	265	249	72	238	20 x 3	10
100	52	162	124	140	190	463	160	638	265	249	72	238	20 x 3	10
125	56	181	124	150	214	497	160	672	265	249	72	238	20 x 3	15
150	56	209	124	170	240	543	160	718	265	249	72	238	20 x 3	20
200	60	263	142	205	335	681	160	856	265	249	82	238	24 x 5	30
250	68	315	142	250	360	751	160	926	265	249	82	238	24 x 5	45
300	78	370	142	290	410	841	160	1016	265	249	82	238	24 x 5	40
350	78	420	197	325	487	925	200	1100	283	254	128	248	36 x 6	70
400	102	478	197	360	537	1010	200	1185	283	254	128	248	36 x 6	90
450	114	530	270	410	589	1112	200	1287	283	254	130	248	36 x 6	110
500	127	584	270	450	649	1212	200	1387	283	254	130	248	36 x 6	95
600	110	762	270	503	813	1500	315	1685	389	336	130	286	36 x 6	140
700	110	890	380	610	890	1680	315	1865	389	336	202	285	40 x 7	120
800	110	1012	320	695	980	1855	315	2040	389	336	202	286	50 x 8	180
900	110	1112	320	795	1097	2072	315	2257	389	336	202	286	50 x 8	220
1000	110	1240	320	875	1205	2260	400	2445	389	339	202	286	50 x 8	300
1200	150	1470	450	1340	1600	3150	400	3335	389	339	284	286	60 x 9	480

A: EN558-1 serie 20 up to DN500

Maximum pressure torque in clean water at room temperature



**FLANGE AND BOLTING DETAILS**

**EN 1092-2 PN 10**

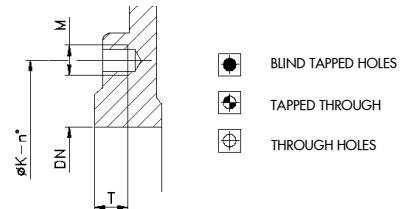
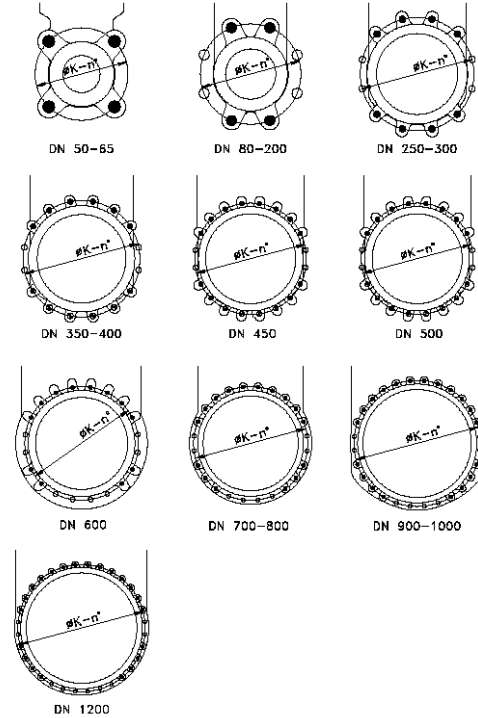
DN	K	n°	M	T	  
50	125	4	M-16	10	4 - 0 - 0
65	145	4	M-16	10	4 - 0 - 0
80	160	8	M-16	12	4 - 0 - 4
100	180	8	M-16	12	4 - 0 - 4
125	210	8	M-16	14	4 - 0 - 4
150	240	8	M-20	14	4 - 0 - 4
200	295	8	M-20	14	4 - 0 - 4
250	350	12	M-20	18	8 - 0 - 4
300	400	12	M-20	21	8 - 0 - 4
350	460	16	M-20	21	6 - 6 - 4
400	515	16	M-24	28	6 - 6 - 4
450	565	20	M-24	30	12 - 4 - 4
500	620	20	M-24	40	8 - 8 - 4
600	725	20	M-27	26	12 - 0 - 8
700	840	24	M-27	20	16 - 0 - 8
800	950	24	M-30	20	16 - 0 - 8
900	1050	28	M-30	20	20 - 0 - 8
1000	1160	28	M-33	20	20 - 0 - 8
1200	1380	32	M-36	35	22 - 0 - 10



**ANSI B16.5, class 150**

DN	K	n°	M	T	  
2"	4 3/4"	4	5/8" UNC	3/8"	4 - 0 - 0
2 1/2"	5 1/2"	4	5/8" UNC	3/8"	4 - 0 - 0
4"	7 1/2"	8	5/8" UNC	3/8"	4 - 0 - 4
5"	8 1/2"	8	3/4" UNC	3/8"	4 - 0 - 4
6"	9 1/2"	8	3/4" UNC	1/2"	4 - 0 - 4
8"	11 3/4"	8	3/4" UNC	1/2"	4 - 0 - 4
10"	14 1/4"	12	7/8" UNC	3/4"	8 - 0 - 4
12"	17"	12	7/8" UNC	3/4"	8 - 0 - 4
14"	18 3/4"	12	1" UNC	7/8"	4 - 4 - 4
16"	21 1/4"	16	1" UNC	1"	12 - 0 - 4
18"	22 3/4"	16	1 1/8" UNC	1"	8 - 4 - 4
20"	25"	20	1 1/8" UNC	1"	12 - 4 - 4
30"	36"	28	1 1/4" UNC	3/4"	18 - 0 - 10
42"	49 1/2"	36	1 1/2" UNC	3/4"	24 - 0 - 12

