

ROUND BY SQUARE PORT KNIFE GATE VALVE

The CR model knife gate is a wafer valve designed for the use in difficult applications. This valve is generally suitable for recycling applications, such as junk or sand traps of pulpers, high density cleaners (HDC) or as silo outlet with solid material. The two piece body with round inlet and square outlet (larger than the inlet) ensures non-jamming.

Sizes: DN 100 to DN 600 (larger diameters on request)

Working pressure:

DN 100 a DN 400 7 kg/cm²
DN 500 a DN 600 4 kg/cm²

Standard flange connection:

DIN PN 10 and ANSI B16.5 (class 150)
(on valve inlet only)
Others: on request

Option: For the square outlet, ORBINOX can also design a square-to-round transition piece

Directives: 2006/42/CE (MACHINES)
97/23/CE (PED) Fluid: Group I(b), II (Cat. I, mod. A)
94/9/CE (ATEX)



All valves are tested prior to shipping in accordance with the standard developed by the Quality Control Department at ORBINOX

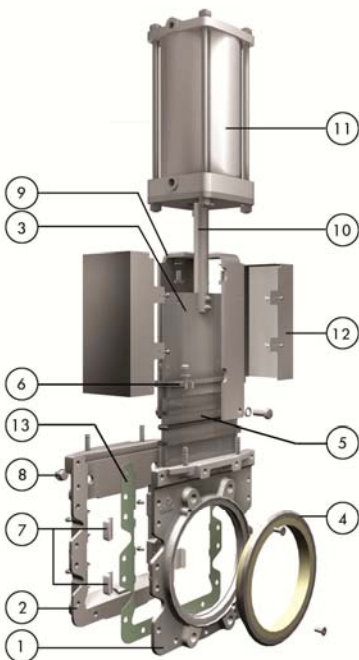

STANDARD PARTS LIST

Part:	Cast Iron:	Stainless Steel:
1- Body	GJL 250 (0.6025)	CF8M (1.4408)
2- Body	GJL 250 (0.6025)	CF8M (1.4408)
3- Gate	2205 (1.4462)	
4- Sleeve	Polyurethane Rubber	
5- Packing	Dynapack (Graphite impregnated PTFE and Aramid yarn combination with an elastomeric core)	
6- Gland Follower	CF8M	
7- Sliders	HWMPE	
8- Cap	Galv. Steel	AISI 316 (1.4404)
9- Yoke	Carbon Steel - Epoxy Coated	
10- Piston Rod	AISI 304 (1.4301)	
11- Cylinder	Aluminium	
12- Gate guards	AISI 304 (1.4301)	
13- Gasket	Aramid fibres	

DESIGN FEATURES

BODY:

Cast two-part bolted body, internally machined and with reinforcing ribs in larger diameters for extra body strength. The internal replaceable gate guides allow for smoother gate traveling. The square outlet (reinforced with sliders) prevents the build-up of contaminants such as staples, wires, etc. For the most severe applications, the body includes standard flush ports to flush out the solids that may interfere with the gate traveling.

GATE:

Duplex stainless steel gate, oversized thickness and polished on both sides, increases its wearing resistance and prevents damage to the seat. This design also allows to perfectly cut through the fluid.

SEAT/POLYURETHANE SLEEVE:

The seat is composed of a highly resistant, long-lasting sleeve, made of polyurethane and with a stainless steel core. This design allows for easy sleeve replacement and avoids gasket installation between the flange and the valve.

PACKING:

Long-life packing with several graphite impregnated PTFE and Aramid yarn combination with an elastomeric core, together with an easy adjusting and access packing gland ensuring a tight seal. Long-life braided packing is available in a wide range of materials.

YOKE OR ACTUATOR SUPPORT:

Made of EPOXY coated steel (stainless steel available on request). Compact design makes it extremely robust even under the most severe conditions. Reinforced design is standard starting from DN 250.

EPOXY COATING:

The EPOXY coating on all ORBINOX cast iron and carbon steel valve bodies and components is electrostatically applied making the valves to be corrosion resistant with a high quality finished surface. The ORBINOX standard colour is RAL-5015 blue.

GATE SAFETY PROTECTION:

ORBINOX automated valves are provided with gate guards in accordance with EU Safety Standards. The design feature prevents any objects from being caught accidentally while the gate is moving.



OTHER OPTIONS

Other materials of construction:

Special stainless steels and alloys such as AISI 317, 254SMO, Hastelloys, Titanium, etc.

Fabricated valves:

ORBINOX designs, produces and delivers special fabricated valves for special process conditions (big sizes and/or high pressures)

SURFACE TREATMENTS

Valve components can be protected or coated for a longer life expectancy, depending on the application and the service conditions.

At ORBINOX we can offer treatments and coatings for the valve components to improve the properties against abrasion (Stellite, Polyurethane...), corrosion (Halar, Rilsan, Galvanised...) and adherence (Polishing, PTFE...).



ATEX



Please contact our ORBINOX representative for info and availability. Some considerations:

- Hand operated CR valves have been subjected to an ignition risk assessment according to standard DIN EN 13463: 1-5 and they are out the scope of application of ATEX Directive. Therefore hand operated valves are suitable for ALL ATEX zones.
- Electrical, pneumatical and hydraulically operated valves must be subject to a conformity assessment of their own and also of the whole unit valve-actuator to get EC Type Approval to Directive 94/9.

We recommend to contact our technical department

MODEL**CR**

TEMPERATURE CHART

SEAT / SLEEVES

PACKING

Material	Max.Temp.(°C)	Applications
Polyurethane (PU)	90	General

Material	Max.Temp.(°C)	pH
Dynapack (DP)	270	2-14
PTFE impregn. synth. fibre (ST)	240	2-13
Braided PTFE (TH)	260	0-14

All of them are reinforced with a stainless steel core. More details and other materials on request

SEAT TYPE

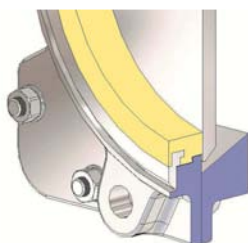

POLYURETHANE

The sealing of the CR valve is achieved through a high resistance elastomer, which improves the watertightness at both the flange and closing area. The sleeve has a stainless core with very good resistance to pressure and working conditions.

DOUBLE ACTING PNEUMATIC CYLINDER

• The standard pneumatic actuator (double acting on-off cylinder) consists of:

- DN ≤ 250: Aluminum barrels
- DN ≥ 300: Composite barrels
- Aluminium covers
- Stainless Steel (AISI 304) piston rod
- Nitrile coated steel piston

• Available from DN 100 to DN 600

• Supply Pressure: min. 3.5 kg/cm² - max. 10 kg/cm².
Actuator designed with 6 kg/cm² air supply

• Reinforced design of support plates (U type) is standard starting from DN 250

• Options (on request):

- Hard anodized barrel and covers
- Stainless Steel barrel and covers
- Over/Undersized cylinder
- Manual override
- Fail safe system
- Limit switches

• Instrumentation (on request):

- Positioners
- Solenoid valves
- Flow regulators
- Air preparation units

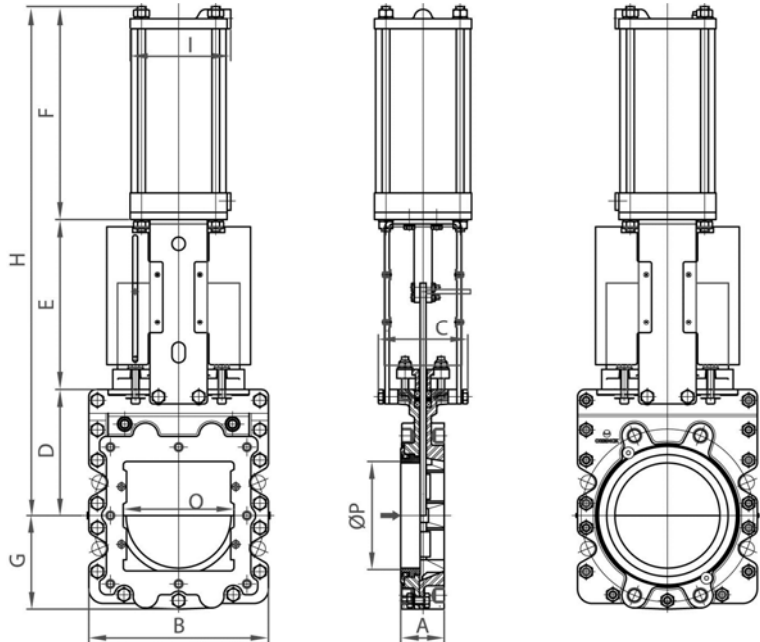

DN	A	B	C	D	E	F	G	H	I	O	P	Weight (kg.)	Std.Cyl.	Connect.
100	52	206	100	140	198	231	110	569	115	95	97	35	C100/115	1/4"G
150	60	252	108	175	237	296	130	708	140	145	146	78	C125/168	1/4"G
200	60	315	123	205	309	358	168	872	175	194	194	89	C160/220	3/8"G
250	69	388	185	250	376	428	194	1054	220	245	247	100	C200/270	3/8"G
300	78	428	185	290	426	478	232	1194	220	294	298	145	C200/320	3/8"G
400	89	560	270	392	574	599	292	1565	277	398	398	268	C250/425	3/8"G
500	114	647	270	450	675	730	339	1855	382	499	479	370	C300/525	1/2"G
600	114	747	270	510	775	830	397	2115	382	600	578	507	C300/625	1/2"G

TRANSITION TYPES

The CR valve can be supplied with a square to round transition piece, that connects the valve square outlet with the round flange or pipe.

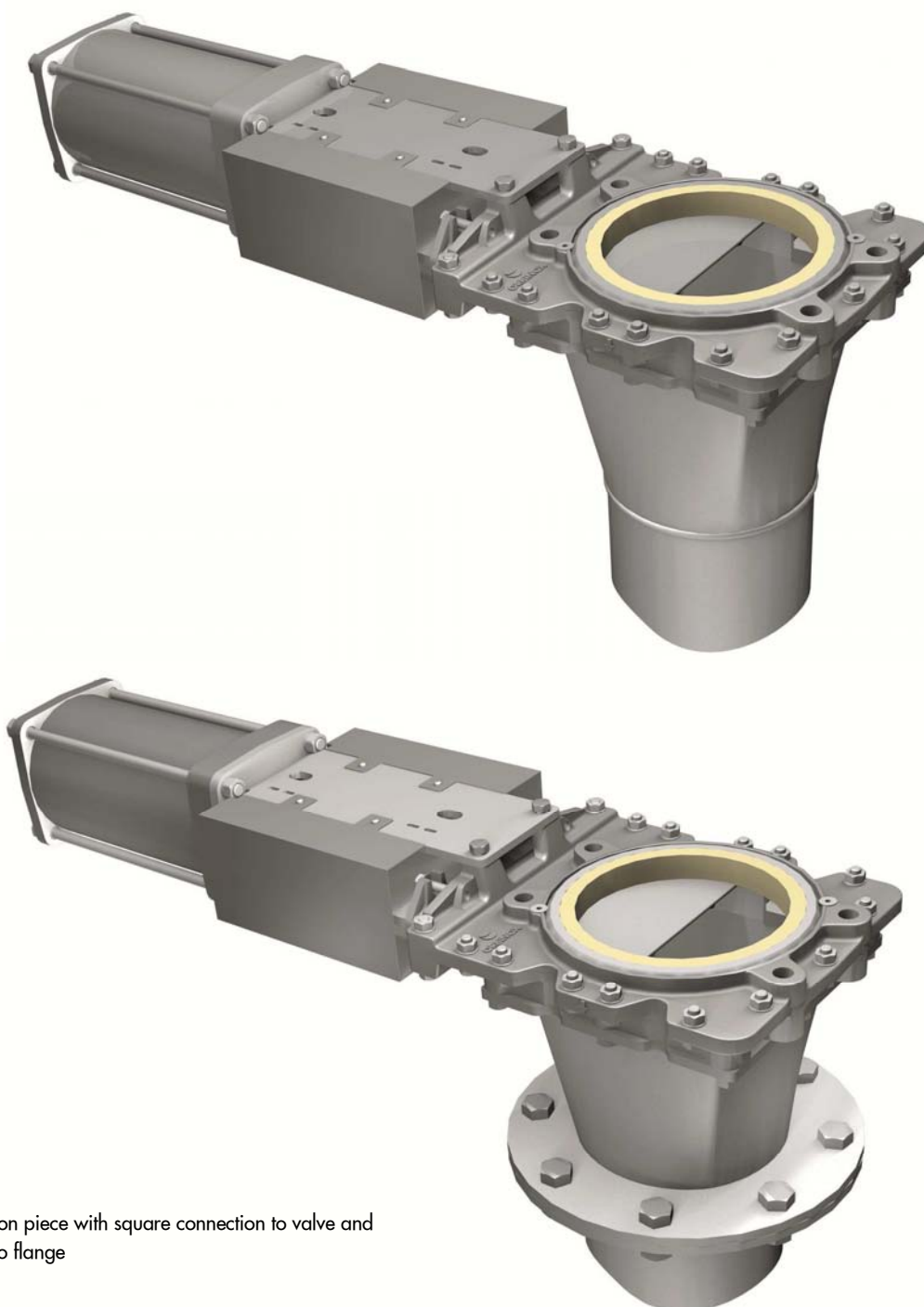

Transition piece with square connection to valve and round to flange

TRANSITION TYPES

Two transition types:

1.- Flange connection

2.- Welding connection

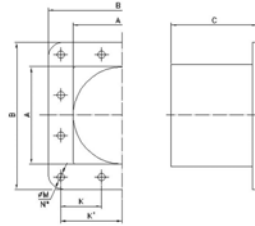
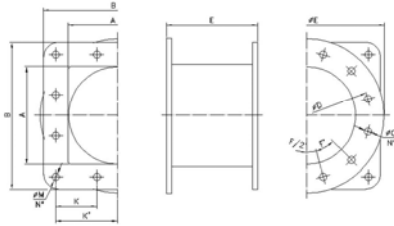

DN	A	B	K	K'	ØM	Qty	FACE TO FACE	
							C	Transition + valve
100	100	210	70	70	14	8	100	152
150	150	260	95	95	14	8	150	210
200	200	320	122.5	122.5	14	8	200	260
250	250	400	150	150	14	8	250	319
300	300	470	124	186	14	12	250	328
400	400	580	154	231	18	12	250	339
500	500	600	187	280.5	18	12	300	414
600	600	720	220	330	20	12	300	414

Flange drilling dimensions

DIN PN10

DN	ØD	ØE	F	G	Qty
100	180	220	45	18	8
150	240	285	45	22	8
200	295	340	45	22	8
250	350	395	30	22	12
300	400	445	30	22	12
400	515	565	22.5	27	16
500	620	670	18	27	20
600	725	780	18	30	20

ANSI B16.5, class 150

DN	ØD	ØE	F	G	Qty
100	190,5	229	45	19	8
150	241,3	279	45	22	8
200	298,4	343	45	22	8
250	361,9	406	30	25	12
300	431,8	483	30	25	12
400	539,7	595	22.5	28	16
500	635	700	18	32	20
600	749,3	815	18	35	20

FLANGE AND BOLTING DETAILS

EN 1092-2 PN10

DN	K	n°	M	T	
100	180	8	M-16	11	4 - 4
150	240	8	M-20	13	4 - 4
200	295	8	M-20	16	4 - 4
250	350	12	M-20	16	8 - 4
300	400	12	M-20	16	12 - 0
400	515	16	M-24	22	12 - 4
500	620	20	M-24	22	16 - 4
600	725	20	M-27	22	16 - 4

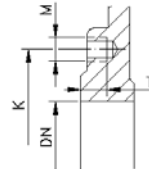
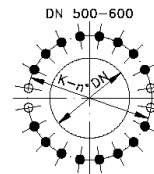
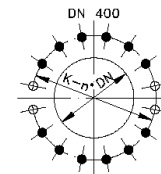
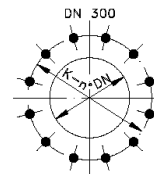
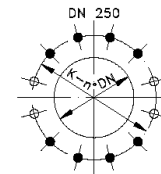
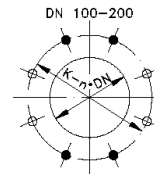

- BLIND TAPPED BOLT HOLES
- THROUGH GOING BORE

ANSI B16.5, class 150

DN	K	n°	M	T	
4"	7 1/2"	8	5/8"UNC	7/16"	4 - 4
6"	9 1/2"	8	3/4"UNC	3/8"	4 - 4
8"	11 3/4"	8	3/4"UNC	5/8"	4 - 4
10"	14 1/4"	12	7/8"UNC	5/8"	8 - 4
12"	17"	12	7/8"UNC	5/8"	12 - 0
16"	21 1/4"	16	1"UNC	7/8"	12 - 4
20"	25"	20	1 1/8"UNC	7/8"	16 - 4
24"	29 1/2"	20	1 1/4"UNC	7/8"	16 - 4

