

**MODEL****EX****SERIES 10**

## WAFER STYLE KNIFE GATE VALVE

The EX(SER.10) model knife gate is an uni-directional wafer valve designed for general industrial service applications. The design of the body and seat assures non-clogging shut off on suspended solids in industries such as:

- Pulp and Paper
- Wastewater treatment plants
- Food and Beverage
- Mining
- Power plants
- Chemical plants
- Bulk handling
- Etc.

**Sizes:** DN 2"/50mm to DN 48"/1200mm (larger diameters on request)

**Working pressure:**

DN 2"/ 50mm to DN 10"/ 250mm	150 psi/(10 kg/cm <sup>2</sup> )
DN 12"/300mm to DN 16"/ 400mm	90 psi/ (6 kg/cm <sup>2</sup> )
DN 18"/450mm	75 psi/ (5 kg/cm <sup>2</sup> )
DN 20"/500mm to DN 24"/ 600mm	60 psi/ (4 kg/cm <sup>2</sup> )
DN 28"/700mm to DN 48"/1200mm	30 psi/ (2 kg/cm <sup>2</sup> )

**Standard flange connection:**

DIN PN 10 and ANSI B16.5 (class 150)

Other flange connections available on request

DIN PN 6	DIN PN 16	DIN PN 25
BS "D" and "E"	ANSI 125	

**Directives:** 2006/42/CE (MACHINES)  
97/23/CE (PED) Fluid: Group 1(b), 2 (Cat. I. mod. A)  
94/9/CE (ATEX)



All valves are tested prior to shipping in accordance with the standard developed by the Quality Control Department at ORBINOX.

### STANDARD PARTS LIST

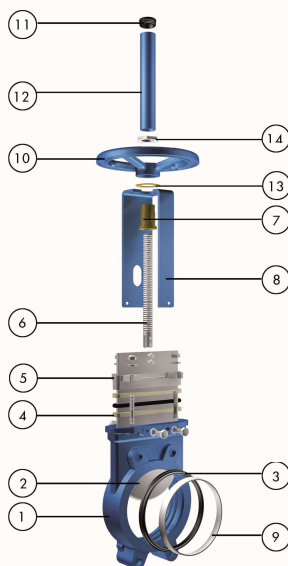

Part:	Cast Iron:	Stainless Steel:
1.- Body	GJL250(GG25)	CF8M
2.- Gate	AISI 304	AISI 316
3.- Seat	Metal/Metal or EPDM	
4.- Packing	PTFE Impreg. Synth. Fibre with an EPDM O-ring (With a EPDM O-Ring)	
5.- Gland Follower	Alum. (DN2"/50mm to DN12"/300mm) or Ductile Iron (DN14"/350mm a DN48"/1200mm)	CF8M
6.- Stem	AISI 430	
7.- Stem nut	Brass	
8.- Yoke	EPOXY-coated Carbon Steel	
9.- "A" ring	AISI 304	AISI 316
10.- Handwheel	GJS400 (GGG40)	
11.- Cap	Plastic	
12.- Stem Protector	EPOXY-coated Carbon Steel	
13.- Friction Washer	Brass	
14.- Nut	Zinc Plated Carbon Steel	



Reserves the right to change specifications without notice

ORBINOX CANADA, ORBINOX USA, ORBINOX BRAZIL, ORBINOX SPAIN, ORBINOX UK, ORBINOX FRANCE, ORBINOX GERMANY, ORBINOX INDIA, ORBINOX CHINA, ORBINOX S.E.A.

[www.orbinox.com](http://www.orbinox.com)

OBX 02/15

Rev.1

EX (SER.10)\_1

**MODEL**

**EX**

**SERIES 10**



## DESIGN FEATURES

### **BODY:**

Wafer style cast monoblock with raised faces and reinforcing ribs in large diameters for extra body strength. Internal cast-in gate wedges and guides allow for a tighter shut-off between gate and seat. Full port design for greater flow capacity and minimal pressure drop. The internal body design avoids any accumulation of solids that would prevent the valve from closing.

### **GATE:**

Stainless steel gate. Gate is polished on both sides to avoid jamming and seat damage. Bottom of the gate edge is machined to a bevel to cut through solids for a tighter seal in the closed position. The thickness and/or material of the gate can be changed on request for higher pressure requirements.

### **SEAT: (resilient)**

Unique design that mechanically locks the seal in the internal of the valve body with a stainless steel retainer ring. Standard EPDM also available in different materials such as Viton, PTFE, etc.

### **PACKING:**

Long-life packing with several layers of braided fibre plus an EPDM o-ring, with an easy access packing gland ensuring a tight seal. Long-life braided packing is available in a wide range of materials.

### **STEM:**

The standard stainless steel stem offers a long corrosion resistant life. For rising stem handwheel actuators only, a stem protector is provided for additional protection against dust while the valve is in the open position.

### **ACTUATORS:**

All actuators supplied by ORBINOX are interchangeable, and supplied with a standard mounting kit for installation purposes on site.

### **YOKE or ACTUATOR SUPPORT:**

Made of EPOXY coated steel (stainless steel available on request). Compact design makes it extremely robust even under the most severe conditions.

### **EPOXY COATING:**

The epoxy coating on all ORBINOX cast iron and carbon steel valve bodies and components is applied by means of an electrostatic process, making the valves corrosion-resistant with a high quality finished surface. The ORBINOX standard colour is RAL-5015 blue.

### **GATE SAFETY PROTECTION:**

ORBINOX automated valves are provided with gate guards in accordance with EU Safety Standards. The design feature prevents any objects from being caught accidentally while the gate is moving.

\* IN EUROPE ONLY

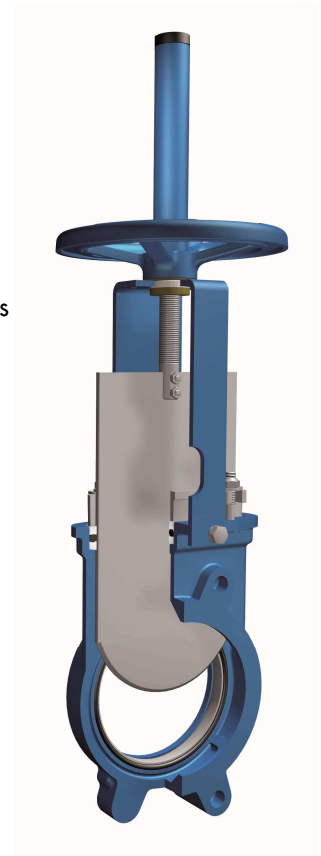

MODEL

EX

SERIES 10



## OTHER OPTIONS

### Bonnet (Fig.1):

Assures tight seal to atmosphere.  
Reduces packing maintenance.

### V-port:

60 degree and pentagonal port design. Selection depends on the desired fluid control type.

### Flush ports (Fig.2):

Allow for cleaning of solids trapped within the body cavities that can obstruct the flow or prevent the valve from closing. Depending on the process, purging can be made with air, steam, liquids, etc.

### Other materials of construction:

Ductile iron, carbon steel, stainless steels (AISI 317, ...), special alloys (254SMO, Hastelloys, ...), Titanium, etc.

### Fabricated valves :

ORBINOX designs, produces and delivers special fabricated valves for special process conditions (big sizes and/or high pressures).

### EXT (full lug design):

Modified version of the EX model with full lug design for end of line applications. Standard flange connection from DIN PN 10, ANSI 150, to AS "D". Sizes available up to DN 24"/600mm.

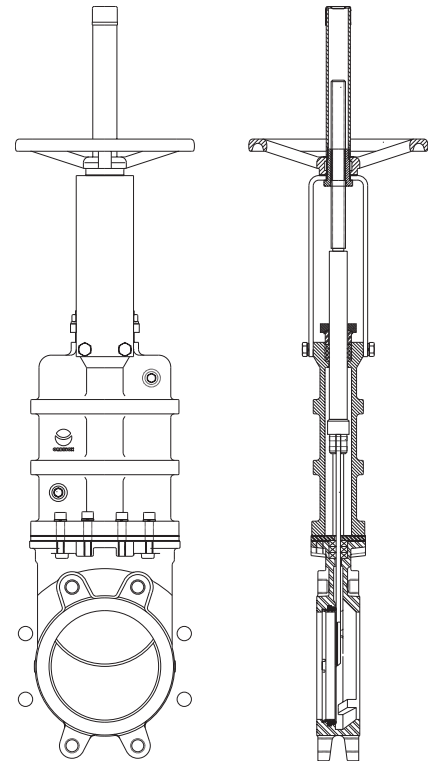

Fig.1

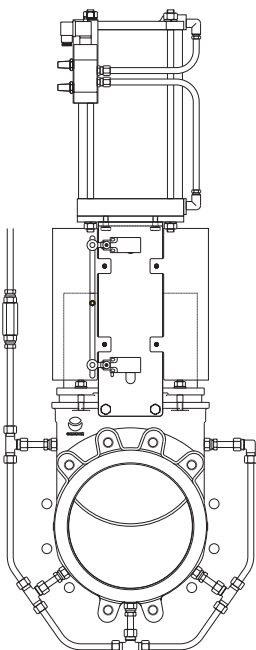

Fig.2

## SURFACE TREATMENTS

Valve components can be protected or coated for a longer life expectancy, depending on the application of the valves and the valve service conditions. At ORBINOX we can offer alternative treatments and coatings for the different valve components to improve their properties against abrasion (Stellite, Polyurethane...), against corrosion (Halar, Rilsan, Galvanised...) and against adherence (Polishing, PTFE...).

## ATEX



Please contact our ORBINOX representative for information and availability.

Some considerations:

- Hand operated EX(SER.10) valves have been subject to an ignition risk assessment according to the DIN EN 13463: 1-5 standard and they are out the scope of application of ATEX Directive. Therefore hand operated valves are suitable for ALL ATEX zones.
- Electrical, pneumatical and hydraulically operated valves must be subject to a conformity assessment of their own and also of the whole unit valve actuator to get EC Type Approval to Directive 94/9.

We recommend consultation with our technical department.

**MODEL**

**EX**

**SERIES 10**

## ACTUATOR TYPES

### MANUAL:

Handwheel (rising stem)  
Handwheel ( non-rising stem)  
Chainwheel  
Lever  
Bevel Gear  
Other (square nut)

### AUTOMATIC:

Electric (rising & non-rising stem)  
Pneumatic (single & double-acting)  
Hydraulic

All actuators supplied by ORBINOX are interchangeable

### ACCESSORIES:

Mechanical Stops  
Actuator manual override  
Positioners  
Proximity Switches  
Stem Extensions

Locking device  
Solenoid valves  
Limit Switches  
Floor stands

Wide range of valve extensions available

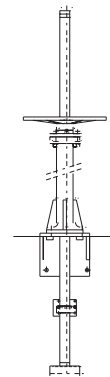

Please contact our Technical Department

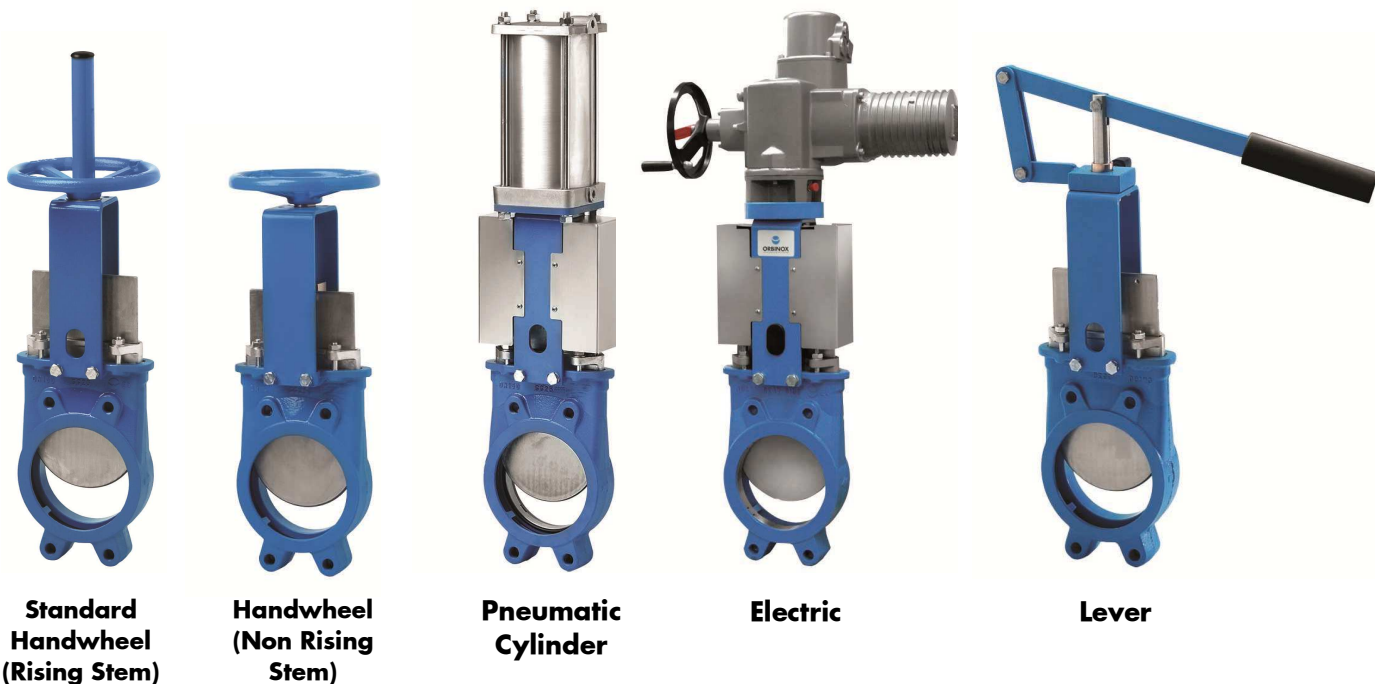

**MODEL****EX****SERIES 10****TEMPERATURE CHART****SEAT / SEALS**

Material	Max.T (F°)	(°C)	Applications
Metal/Metal	>482	>250	High temp./Low tightness
EPDM (E)	248	120	Acids and non mineral oils
Nitril (N)	248	120	Resistance to petroleum products
Viton (V)	392	200	Chemical service /High temp.
Silicon (S)	482	250	Food service / High temp.
PTFE (T)	482	250	Corrosion resistance

**PACKING**

Material	Max.T (F°)	(°C)	pH
Dry cotton (AS)	122	50	6-8
PTFE impregn. synth. fibre (ST)	464	240	2-13
Braided PTFE (TH)	500	260	0-14
Graphited (GR)	1112	600	0-14
Ceramic fibre (FC)	2192	1200	--

NOTE: all types include an elastomere O-ring (same material as seal), excluding TH, GR and FC.

More details and other materials under request

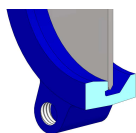
**SEAT TYPES****METAL/METAL**

For applications with:

- High temperature
- High density media application
- In those cases when full tightness is not required

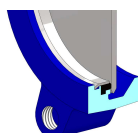
**RESILIENT TYPE "A"**

- Standard resilient seat.
- Temperature limitations according to the selected seat material. Review the above chart or contact our Technical Department for more information.
- Seat with replaceable retainer ring

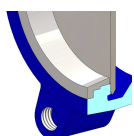
**TYPE "B" SEAT (metal/metal)**

For applications with:

- High temperature
- High density media application
- In those cases when full tightness is not required
- Replaceable design without dismantling the valve

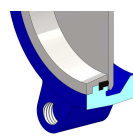
**TYPE "B" SEAT (resilient)**

- Temperature limitations according to the selected seat material. Review the above chart or contact our Technical Department for more information.
- Replaceable and reinforced seat ring available in different materials such as: stainless steel, CA1 5, Ni Hard,...

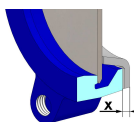
**DEFLECTION CONE "C"**

• Deflects the media away from any valve internal exposed parts (gate guides, seat,...)

- Material: AISI 316, CA15, Ni-Hard, etc.
- Face-to-face dimension increases:  
 DN 2"/50mm to DN 10"/250mm X = 0.35"/9mm  
 DN 12"/300mm to DN 24"/600mm X = 0.47"/12mm  
 Larger diameters on request

**VALVE EXTENSIONS**

The extension on a valve allows the operator to open or close the valve from a distance. Different types of extensions can be used depending on the application and the distance from the gate to the actuator.

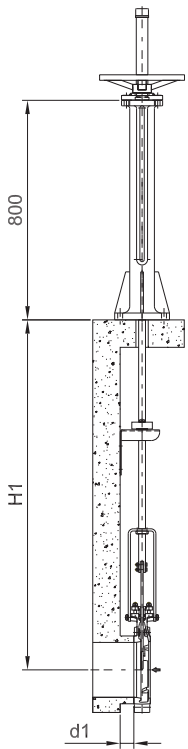

Fig.1

**1.- Floor stand**

- A pipe of the required length is added to the valve stem.
- Stem and yoke assembly remain in the original position.
- A floor stand is normally used at the top of the extension for actuator installation purposes.
- Required dimensions:  
 H1: distance from centre line of the pipe to the base of the floor.  
 d1: (wall bracket) distance from the wall to the face of the connecting flange.

**Notes:**

- a- Any type of actuator can be mounted on the floor stand such as Handwheel, Gear, Electric, etc.
- b- A wall bracket (Fig. A) is recommended at every 59"/1.5m. This prevents any deviation or buckling of the extension rod.
- c- Standard construction of the floor stand is fabricated carbon steel. Other materials are available on request. (Fig. 1)
- d- A position indicator (optional) can be installed for easy visibility of the percentage of opening of the valve.
- e- Availability of supports for actuator floor stands (Fig. 2) upon request.

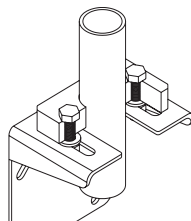

Fig. A

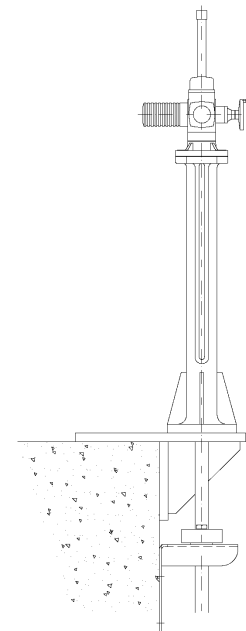
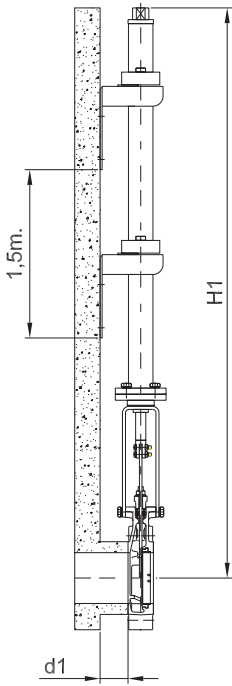

Fig.2

**STANDARD PARTS LIST**

Parts:	Material:
Spindle	AISI 303
Stem	AISI 304
Wall bracket	Carbon Steel- Epoxy coated
Slider	Nylon
Brass	Cast Iron- Epoxy coated

## 2.- Tube



- Stem and yoke assembly remains in its original position.
- Handwheel is replaced by a tube, which rotates at the time of operating the valve.
- Stem rises and lowers within the tube.
- Ideal for surface box operation, valve can be operated with a T-bar and a square nut.
- Required dimensions:  
H1: distance from centre line of the pipe to the base of the floor.  
d1: (wall bracket) distance from the wall to the face of the connecting flange.

### Notes:

1. Handwheel or square nut operated only.
2. A wall bracket (Fig. A) is recommended at every 59"/1.5m. This prevents any deviation or buckling of the extension rod.
3. Standard construction of the extension is carbon steel epoxy coated. Other materials are available on request.

## 3 - Universal joint

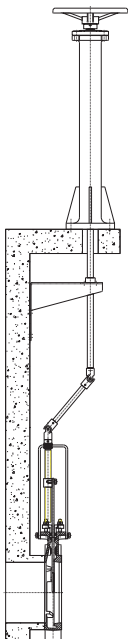

- Universal joints are used in those cases where the alignment of the extension between valve and actuator is not feasible.
- Please contact our technical department for more information.

## 4 - Extended support plates

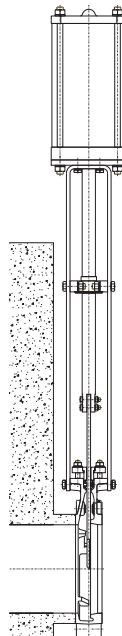

- Ideal where long extensions are not required.
- Guide bearing is installed at the mid point to prevent any deflection of the rod.

**MODEL****EX****SERIES 10****HANDWHEEL (rising stem)**

- Standard handwheel actuator
- Consists of:
  - Handwheel: Epoxy coated Cast Iron
  - Stem
  - Stem nut
  - Stem protector
- Available from DN 2"/50mm to DN 40"/1000mm
- Options:
  - Locking Device
  - Extensions

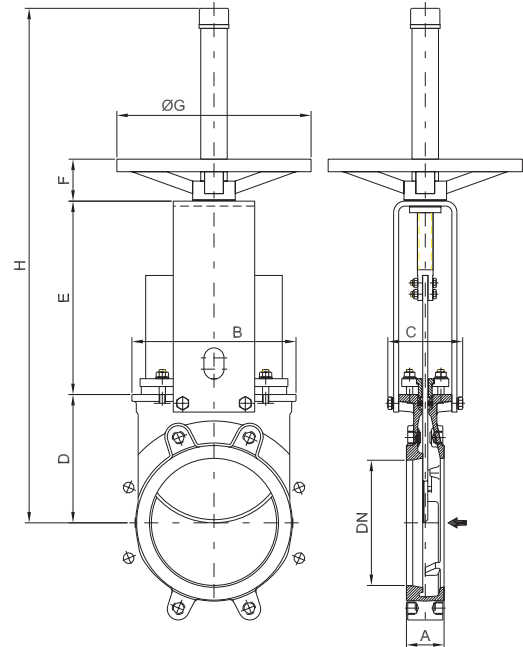

DN(" / mm)	A	B	C	D	E	F	ØG	H	Weight (lbs./kg.)
2"/50	1,57/40	4,68/119	4/100	4,13/105	5,07/129	1,85/47	8,86/225	16,53/420	15/7
2,5"/65	1,57/40	5,27/134	4/100	4,53/115	5,79/146	1,85/47	8,86/225	17,71/450	18/8
3"/80	2/50	5,87/149	4/100	4,88/124	6,37/162	1,85/47	8,86/225	18,70/475	20/9
4"/100	2/50	6,65/169	4/100	5,52/140	7,36/187	1,85/47	8,86/225	20,47/520	24/11
5"/125	2/50	7,08/180	4/100	6/150	8,30/211	1,85/47	8,86/225	23,62/600	33/15
6"/150	2,36/60	8,26/210	4/100	6,89/175	9,33/237	1,85/47	8,86/225	25,67/652	40/18
8"/200	2,36/60	10,31/262	4,68/119	8,07/205	12,16/309	2,64/67	12,20/310	32,36/822	66/30
10"/250	2,75/70	12,52/318	4,80/122	10/250	14,33/364	2,64/67	12,20/310	40,23/1022	97/44
12"/300	2,75/70	14,64/372	4,80/122	12/300	16,30/414	2,64/67	12,20/310	44,17/1122	128/58
14"/350	3,78/96	16,97/431	7,75/197	13,30/338	19,13/486	2,60/66	16,14/410	52,08/1323	217/96
16"/400	3,93/100	19,13/486	7,75/197	15,43/392	21,10/536	2,60/66	16,14/410	56,18/1427	274/124
18"/450	4,17/106	21,26/540	7,91/201	17,00/432	23,15/588	2,60/66	21,65/550	62,75/1594	370/168
20"/500	4,33/110	23,70/602	7,91/201	19,09/485	25,51/648	2,60/66	21,65/550	67,20/1707	424/192
24"/600	4,33/110	27,87/708	7,91/201	23,23/590	29,44/748	2,60/66	21,65/550	79,60/2022	540/245
28"/700	4,33/110	32,83/834	14,96/380	27/686	35,04/890	2,92/74	31,50/800	109,37/2778	893/405
30"/750	4,33/110	34,80/884	14,96/380	29,90/760	37,20/945	2,92/74	31,50/800	114,17/2900	1003/455
32"/800	4,33/110	39,96/1015	12,60/320	31,14/791	38,94/989	2,92/74	31,50/800	117,32/2980	1129/512
36"/900	4,33/110	40,94/1040	12,60/320	35,23/895	45,01/1118	2,92/74	31,50/800	126,57/3215	1499/680
40"/1000	4,33/110	45,12/1146	12,60/320	38,28/975	48,03/1220	2,92/74	31,50/800	133,86/3400	1907/865

Reserves the right to change specifications without notice

OBX 02/15

Rev.1

ORBINOX CANADA, ORBINOX USA, ORBINOX BRAZIL, ORBINOX SPAIN, ORBINOX UK, ORBINOX FRANCE, ORBINOX GERMANY, ORBINOX INDIA, ORBINOX CHINA, ORBINOX S.E.A. EX (SER.10)\_8

[www.orbinox.com](http://www.orbinox.com)



**MODEL****EX****SERIES 10**

## HANDWHEEL (non-rising stem)

- Recommended for installation where space is limited
- Consists of:
  - Handwheel: Epoxy coated Cast Iron
  - Stem
  - Yoke bushing
  - Stem nut fixed to the gate
- Available from DN 2"/50mm to DN 40"/1000mm
- Options:
  - Locking Device
  - Extension
  - Square Nut Drive

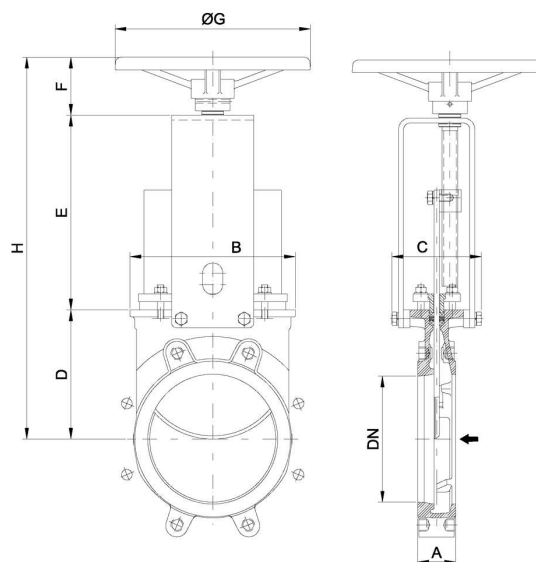

DN(" / mm)	A	B	C	D	E	F	ØG	H
2" / 50	1,57/40	4,68/119	5/125	4,13/105	5,20/132	3,07/78	8,86/225	12,40/315
2,5" / 65	1,57/40	5,27/134	5/125	4,53/115	5,87/149	3,07/78	8,86/225	13,46/342
3" / 80	2/50	5,87/149	5/125	4,88/124	6,50/165	3,07/78	8,86/225	14,44/367
4" / 100	2/50	6,65/169	5/125	5,52/140	7,48/190	3,07/78	8,86/225	16,06/408
5" / 125	2/50	7,08/180	5/125	6/150	8,42/214	3,07/78	8,86/225	17,40/442
6" / 150	2,36/60	8,26/210	5/125	6,89/175	9,45/240	3,07/78	8,86/225	19,40/493
8" / 200	2,36/60	10,31/262	5,60/142	8,07/205	12,00/305	3,62/92	12,20/310	23,70/602
10" / 250	2,75/70	12,52/318	4,60/142	10/250	14,17/360	3,62/92	12,20/310	27,64/702
12" / 300	2,75/70	14,64/372	4,60/142	12/300	16,17/410	3,62/92	12,20/310	31,57/802
14" / 350	3,78/96	16,97/431	7,75/197	13,30/338	19,17/487	4,33/110	16,14/410	36,81/935
16" / 400	3,93/100	19,13/486	7,75/197	15,43/392	21,14/537	4,33/110	16,14/410	40,90/1039
18" / 450	4,17/106	21,26/540	7,91/201	17,00/432	23,19/589	4,37/111	21,65/550	44,56/1132
20" / 500	4,33/110	23,70/602	7,91/201	19,09/485	25,55/649	4,37/111	21,65/550	49,01/1245
24" / 600	4,33/110	27,87/708	7,91/201	23,23/590	29,45/748	4,37/111	21,65/550	57,04/1449
28" / 700	4,33/110	32,83/834	14,96/380	27/686	35,43/900	5,94/151	31,50/800	68,38/1737
30" / 750	4,33/110	34,80/884	14,96/380	29,90/760	37,20/945	5,94/151	31,50/800	73,07/1856
32" / 800	4,33/110	39,96/1015	12,60/320	31,14/791	39,25/997	5,94/151	31,50/800	76,34/1939
36" / 900	4,33/110	40,94/1040	12,60/320	35,23/895	44,40/1128	5,94/151	31,50/800	85,59/2174
40" / 1000	4,33/110	45,27/1150	12,60/320	38,28/975	49,40/1255	5,94/151	31,50/800	93,74/2381

**MODEL****EX****SERIES 10**

## CHAINWHEEL

- Recommended for elevated installations
- Consists of:
  - Chainwheel: Epoxy coated Cast Iron
  - Stem
  - Stem nut
  - Stem protector
- Available from DN 2"/50mm to DN 24"/600mm
- Options:
  - Locking Device
  - Extension
  - Rising Stem and Non-rising Stem

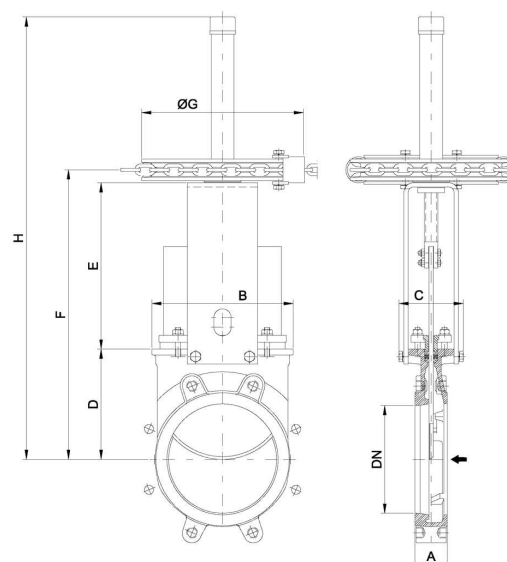

DN(" / mm)	A	B	C	D	E	F	ØG	H
2"/50	1,57/40	4,68/119	4/100	4,13/105	5,07/129	9,96/253	8,86/225	16,53/420
2,5"/65	1,57/40	5,27/134	4/100	4,53/115	5,79/146	11,02/280	8,86/225	17,71/450
3"/80	2/50	5,87/149	4/100	4,88/124	6,37/162	12,00/305	8,86/225	18,70/475
4"/100	2/50	6,65/169	4/100	5,52/140	7,36/187	13,66/347	8,86/225	20,47/520
5"/125	2/50	7,08/180	4/100	6/150	8,30/211	14,96/380	8,86/225	23,62/600
6"/150	2,36/60	8,26/210	4/100	6,89/175	9,33/237	16,97/431	8,86/225	25,67/652
8"/200	2,36/60	10,31/262	4,68/119	8,07/205	12,16/309	21,18/538	11,81/300	32,36/822
10"/250	2,75/70	12,52/318	4,80/122	10/250	14,33/364	25,11/638	11,81/300	40,23/1022
12"/300	2,75/70	14,64/372	4,80/122	12/300	16,30/414	29,05/738	11,81/300	44,17/1122
14"/350	3,78/96	16,97/431	7,75/197	13,30/338	19,13/486	33,70/856	17,87/454	52,08/1323
16"/400	3,93/100	19,13/486	7,75/197	15,43/392	21,10/536	37,79/960	17,87/454	56,18/1427
18"/450	4,17/106	21,26/540	7,91/201	17,00/432	23,15/588	41,41/1052	17,87/454	62,75/1594
20"/500	4,33/110	23,70/602	7,91/201	19,09/485	25,51/648	45,87/1165	17,87/454	67,20/1707
24"/600	4,33/110	27,87/708	7,91/201	23,23/590	29,44/748	53,93/1370	17,87/454	79,60/2022

**MODEL****EX****SERIES 10****LEVER**

- Recommended for quick opening and closing
- Consists of:
  - Lever
  - Stem
  - Yoke sleeve
  - Lever lock
- Available from DN 2"/50mm to DN 12"/300mm

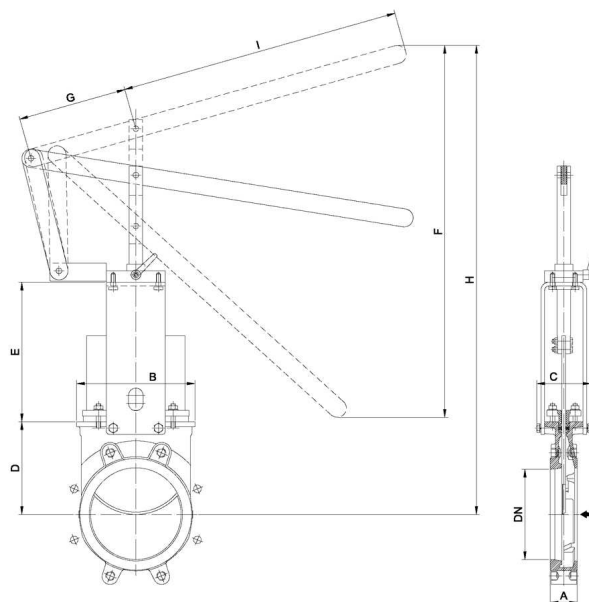

DN(″/mm)	A	B	C	D	E	F	G	H	I
2″/50	1,57/40	4,68/119	4/100	4,13/105	5,07/129	10,08/256	5,90/150	16,06/408	12,40/315
2,5″/65	1,57/40	5,27/134	4/100	4,53/115	5,79/146	10,20/259	5,90/150	17,12/435	12,40/315
3″/80	2/50	5,87/149	4/100	4,88/124	6,37/162	12,08/307	5,90/150	20,03/509	12,40/315
4″/100	2/50	6,65/169	4/100	5,52/140	7,36/187	17,28/439	5,90/150	25,08/637	16,33/415
5″/125	2/50	7,08/180	4/100	6/150	8,30/211	20,83/529	5,90/150	29,72/755	16,33/415
6″/150	2,36/60	8,26/210	4/100	6,89/175	9,33/237	24,40/620	5,90/150	35,23/895	16,33/415
8″/200	2,36/60	10,31/262	4,68/119	8,07/205	12,16/309	32,36/822	9,25/235	40,86/1038	24,40/620
10″/250	2,75/70	12,52/318	4,80/122	10/250	14,33/364	39,17/995	9,25/235	51,45/1307	24,40/620
12″/300	2,75/70	14,64/372	4,80/122	12/300	16,30/414	45,90/1166	9,25/235	62,12/1578	24,40/620

**MODEL****EX****SERIES 10****GEAR**

- Recommended for valves larger than DN 14"/350mm and working pressures greater than 50psi (3.5 kg/cm<sup>2</sup>)
- Consists of:
  - Stem
  - Yoke
  - Bevel Gear Actuator with Handwheel
- Available from DN 8"/200mm to DN 50"/1200mm
- Options:
  - Locking device
  - Extension
  - Chainwheel
  - Rising stem and non-rising stem
- Standard reduction ratio of 4:1

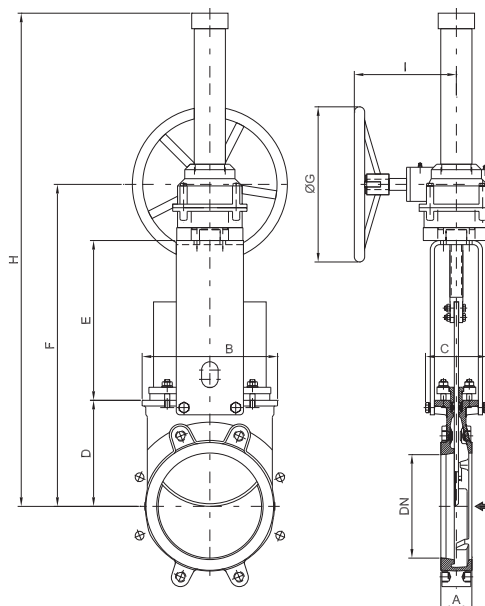

DN(" / mm)	A	B	C	D	E	F	ØG	H	I
8"/200	2,36/60	10,31/262	4,68/119	8,07/205	12,16/309	23,00/584	12/300	39,13/994	7,87/200
10"/250	2,75/70	12,52/318	4,80/122	10/250	14,33/364	26,93/684	12/300	43,07/1094	7,87/200
12"/300	2,75/70	14,64/372	4,80/122	12/300	16,30/414	30,86/784	12/300	47/1194	7,87/200
14"/350	3,78/96	16,97/431	7,75/197	13,30/338	18,58/472	33,74/857	18/450	65,24/1657	10,31/262
16"/400	3,93/100	19,13/486	7,75/197	15,43/392	20,55/522	37,83/961	18/450	69,33/1761	10,31/262
18"/450	4,17/106	21,26/540	7,91/201	17,00/432	22,60/574	41,46/1053	18/450	72,95/1853	10,31/262
20"/500	4,33/110	23,70/602	7,91/201	19,09/485	24,96/634	45,90/1166	18/450	77,40/1966	10,31/262
24"/600	4,33/110	27,87/708	7,91/201	23,23/590	28,89/734	53,97/1371	18/450	85,47/2171	10,31/262
28"/700	4,33/110	32,83/834	14,96/380	27/686	35,04/890	63,90/1623	18/450	95,39/2423	10,31/262
30"/750	4,33/110	34,80/884	14,96/380	29,90/760	37,20/945	69,09/1755	18/450	100,59/2555	10,31/262
32"/800	4,33/110	39,96/1015	12,60/320	31,14/791	39,09/993	74,25/1886	18/450	115,19/2926	10,24/260
36"/900	4,33/110	40,94/1040	12,60/320	35,23/895	44,21/1123	83,46/2120	26/650	124,41/3160	11,34/288
40"/1000	4,33/110	45,12/1146	12,60/320	38,28/975	48,03/1220	90,62/2302	26/650	131,57/3342	11,34/288
48"/1200	6/150	54,72/1390	17,71/450	40,82/1037	59,92/1522	106,10/2695	33/850	154,92/3935	14,37/365

**MODEL**

**EX**

**SERIES 10**



**PNEUMATIC CYLINDER**

- The standard pneumatic actuator (double acting on-off cylinder) consists of:
  - DN ≤ 10"/250mm: Aluminum barrels
  - DN ≥ 12"/300mm: Composite barrels
  - Aluminum end covers
  - Stainless steel (AISI 304) piston rod
  - Nitrile coated steel piston
- Available from DN 2"/50mm to DN40"/ 1000mm
- Supply Pressure: min. 50psi(3.5 kg/cm<sup>2</sup>)- max. 150psi (10 kg/cm<sup>2</sup>).
- Actuator designed with 85psi(6 kg/cm<sup>2</sup>) air supply.
- For valves installed in a horizontal position, we recommend U-type support plates and/or actuator support.
- Options:
  - Hard anodized barrel and covers
  - Stainless steel barrel and covers
  - Over/Undersized cylinder
  - Manual override
  - Fail safe system (Page EX-14)
  - Limit switches
- Instrumentation (on request):
  - Positioners
  - Solenoid valves
  - Flow regulators
  - Air preparation units

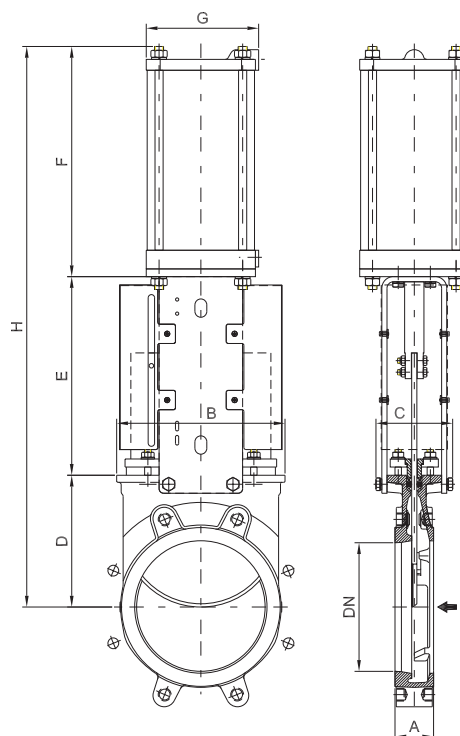

DN(" /mm)	A	B	C	D	E	F	G	H	Weight (lbs./kg.)	Standard Cyl.	Connect.
2"/50	1,57/40	4,68/119	4/100	4,13/105	5,07/129	7,00/178	4,53/115	16,22/412	20/9	C4"-2.44"/(100-62)	¼" G
2,5"/65	1,57/40	5,27/134	4/100	4,53/115	5,79/146	7,60/193	4,53/115	17,87/454	22/10	C4"-3.03"/(100-77)	¼" G
3"/80	2/50	5,87/149	4/100	4,88/124	6,37/162	8,31/211	4,53/115	19,56/497	24/11	C4"-3.74"/(100-95)	¼" G
4"/100	2/50	6,65/169	4/100	5,52/140	7,36/187	9,09/231	4,53/115	21,96/558	30/14	C4"-4.52"/(100-115)	¼" G
5"/125	2/50	7,08/180	4/100	6/150	8,30/211	10,67/271	5,51/140	24,88/632	44/20	C5"-5.52"/(125-143)	¼" G
6"/150	2,36/60	8,26/210	4/100	6,89/175	9,33/237	11,65/296	5,51/140	27,87/708	55/25	C5"-6.61"/(125-168)	¼" G
8"/200	2,36/60	10,31/262	4,68/119	8,07/205	12,16/309	14,09/358	6,89/175	34,33/872	97/44	C6.30"-8.66"/(160-220)	¼" G
10"/250	2,75/70	12,52/318	4,80/122	10/250	14,33/364	16,85/428	8,66/220	41,02/1042	148/67	C8"-10.62"/(200-270)	3/8" G
12"/300	2,75/70	14,64/372	4,80/122	12/300	16,29/414	18,82/478	8,66/220	46,93/1192	181/82	C8"-12.60"/(200-320)	3/8" G
14"/350	3,78/96	16,97/431	7,75/197	13,30/338	19,68/500	21,61/549	10,90/277	54,60/1387	298/135	C10"-14.76"/(250-375)	3/8" G
16"/400	3,93/100	19,13/486	7,75/197	15,43/392	21,65/550	23,58/599	10,90/277	60,67/1541	364/165	C10"-16.73"/(250-425)	3/8" G
18"/450	4,17/106	21,26/540	10,63/270	17,00/432	23,94/598	26,77/680	15,03/382	67,32/1710	485/220	C12"-18.70"/(300-475)	½" G
20"/500	4,33/110	23,70/602	10,63/270	19,09/485	25,90/658	28,74/730	15,03/382	73,74/1873	617/280	C12"-20.67"/(300-525)	½" G
24"/600	4,33/110	27,87/708	10,63/270	23,23/590	29,84/758	32,68/830	15,03/382	85,71/2178	727/330	C12"-24.60"/(300-625)	½" G
28"/700	4,33/110	32,83/834	14,96/380	27/686	34,45/875	38,77/985	17,48/444	100,24/2546	1146/520	C14"-28.74"/(350-730)	¾" G
30"/750	4,33/110	34,80/884	14,96/380	29,90/760	36,61/930	40,75/1035	17,48/444	107,28/2725	1290/585	C14"-30.70"/(350-780)	¾" G
32"/800	4,33/110	39,96/1015	12,60/320	31,14/791	38,34/974	42,77/1085	17,48/444	112,20/2850	1433/650	C14"-32.68"/(350-830)	¾" G
36"/900	4,33/110	40,94/1040	12,60/320	35,23/895	43,50/1105	47,32/1202	20,27/515	126,06/3202	1874/850	C16"-36.61"/(400-930)	¾" G
40"/1000	4,33/110	45,12/1146	12,60/320	38,28/975	47,91/1217	47,91/1296	20,27/515	137,32/3488	2334/1060	C16"-40.55"/(400-1030)	¾" G

Reserves the right to change specifications without notice

OBX 02/15

Rev.1

ORBINOX CANADA, ORBINOX USA, ORBINOX BRAZIL, ORBINOX SPAIN, ORBINOX UK, ORBINOX FRANCE, ORBINOX GERMANY, ORBINOX INDIA, ORBINOX CHINA, ORBINOX S.E.A. EX (SER.10)\_13

www.orbinox.com

MODEL

EX

SERIES 10

## FAIL SAFE SYSTEM

### SINGLE ACTING (SPRING RETURN)

- This actuator (single acting cylinder) consists of:
  - Aluminium barrel and covers
  - Ductile Iron or carbon steel spring cap
  - Steel spring
  - Stainless Steel (AISI 304) piston rod
  - Nitrile coated steel piston
- Available from DN 2"/50mm to DN 8"/200mm
- Supply pressure: min. 71psi(5 kg/cm<sup>2</sup>) - max. 150psi(10 kg/cm<sup>2</sup>)
- Options:
  - Fail open
  - Fail close

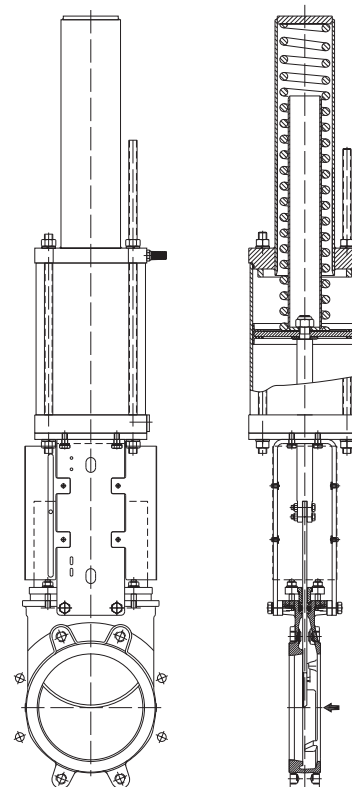
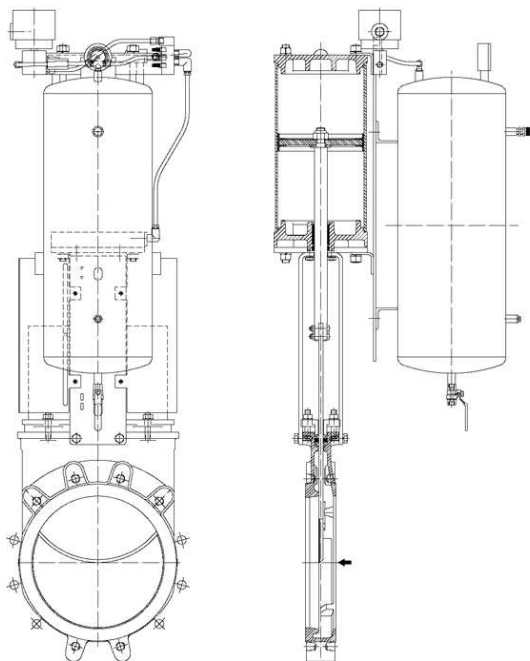

### SINGLE ACTING (VOLUME TANK)

- This safety system consists on: double acting pneumatic cylinder, volume tank and all the necessary elements according to the available options (solenoid valve, spool valve,...)
- Available for all diameters
- Supply Pressure: min. 50psi/(3.5 kg/cm<sup>2</sup>) - max.150psi/ (10 kg/cm<sup>2</sup>)

**MODEL**

**EX**

**SERIES 10**



**ELECTRIC ACTUATOR**

- Consists of:
  - Electric actuator
  - Rising stem
  - Motor support yoke flange acc. to ISO 5210 / DIN 3338
- The standard electric motor is equipped with:
  - Manual emergency operation
  - Limit switches (open/closed)
  - Torque switches
- Available from DN 2"/50mm to DN 48"/1200mm
- Wide range of types and marks available to meet customer's needs
- Option:
  - Non rising stem

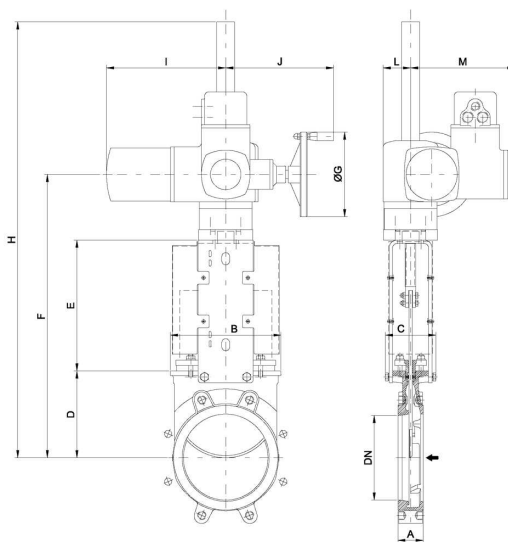

DN <sup>("/mm)</sup>	A	B	C	D	E	F	ØG	H	I	J	L	M	Stem Ø x pitch	Torque (ft.LBS/Nm)
2"/50	1,57/40	4,68/119	4/100	4,13/105	5,07/129	14,84/377	6,30/160	21,53/547	10,43/265	9,80/249	2,44/62	9,37/238	0.79 x 0.16/20 x 4	7.4/10
2.5"/65	1,57/40	5,27/134	4/100	4,53/115	5,79/146	15,90/404	6,30/160	22,60/574	10,43/265	9,80/249	2,44/62	9,37/238	0.79 x 0.16/20 x 4	7.4/10
3"/80	2/50	5,87/149	4/100	4,88/124	6,37/162	16,88/429	6,30/160	23,58/599	10,43/265	9,80/249	2,44/62	9,37/238	0.79 x 0.16/20 x 4	7.4/10
4"/100	2/50	6,65/169	4/100	5,52/140	7,36/187	18,50/470	6,30/160	25,19/640	10,43/265	9,80/249	2,44/62	9,37/238	0.79 x 0.16/20 x 4	7.4/10
5"/125	2/50	7,08/180	4/100	6/150	8,30/211	19,84/504	6,30/160	26,53/674	10,43/265	9,80/249	2,44/62	9,37/238	0.79 x 0.16/20 x 4	11.1/15
6"/150	2,36/60	8,26/210	4/100	6,89/175	9,33/237	21,85/555	6,30/160	41,55/1055	10,43/265	9,80/249	2,44/62	9,37/238	0.79 x 0.16/20 x 4	14.8/20
8"/200	2,36/60	10,31/262	4,80/122	8,07/205	12,16/309	26,33/669	6,30/160	46,02/1169	10,43/265	9,80/249	2,44/62	9,37/238	0.94 x 0.2/24 x 5	22.2/30
10"/250	2,75/70	12,52/318	4,80/122	10/250	14,33/364	30,27/769	6,30/160	49,96/1269	10,43/265	9,80/249	2,44/62	9,37/238	0.94 x 0.2/24 x 5	33.3/45
12"/300	2,75/70	14,64/372	4,80/122	12/300	16,30/414	34,21/869	6,30/160	53,89/1369	10,43/265	9,80/249	2,44/62	9,37/238	0.94 x 0.2/24 x 5	29.50/40
14"/350	3,78/96	16,97/431	7,75/197	13,30/338	19,13/472	37,00/940	7,87/200	56,69/1440	11,14/283	10/254	2,55/65	9,76/248	1.42 x 0.24/36 x 6	51.8/70
16"/400	3,93/100	19,13/486	7,75/197	15,43/392	21,73/552	41,10/1044	7,87/200	60,78/1544	11,14/283	10/254	2,55/65	9,76/248	1.42 x 0.24/36 x 6	66.38/90
18"/450	4,17/106	21,26/540	10,63/270	17,00/432	24,01/610	46,14/1172	7,87/200	65,82/1672	11,14/283	10/254	2,55/65	9,76/248	1.42 x 0.24/36 x 6	81.4/110
20"/500	4,33/110	23,70/602	10,63/270	19,09/485	26,37/670	50,39/1280	7,87/200	70,07/1780	11,14/283	10/254	3,58/91	9,76/248	1.42 x 0.24/36 x 6	70.06/95
24"/600	4,33/110	27,87/708	10,63/270	23,23/590	31,49/800	61,61/1565	12,40/315	81,29/2065	15,31/389	13,22/336	3,58/91	11,25/286	1.42 x 0.24/36 x 6	103.26/140
28"/700	4,33/110	32,83/834	14,96/380	27/686	35,43/900	69,40/1763	12,40/315	112,04/2846	15,31/389	13,22/336	3,58/91	11,25/286	1.57 x 0.27/40 x 7	88.50/120
30"/750	4,33/110	34,80/884	14,96/380	29,90/760	37,20/945	74,09/1882	12,40/315	116,73/2965	15,31/389	13,22/336	3,58/91	11,25/286	1.57 x 0.27/40 x 7	103.26/140
32"/800	4,33/110	39,96/1015	12,60/320	31,14/791	38,58/980	76,69/1948	12,40/315	110,33/3031	15,31/389	13,22/336	3,58/91	11,25/286	1.97 x 0.31/50 x 8	132.76/180
36"/900	4,33/110	40,94/1040	12,60/320	35,23/895	42,79/1087	84,92/2157	15,74/400	127,55/3240	15,31/389	13,34/339	3,58/91	11,25/286	1.97 x 0.31/50 x 8	163.74/220
40"/1000	4,33/110	45,12/1146	12,60/320	38,28/975	47,24/1200	92,51/2350	15,74/400	135,07/3431	15,31/389	13,34/339	3,58/91	11,25/286	1.97 x 0.31/50 x 8	221.27/300
48"/1200	5,90/150	45,11/1390	17,71/450	40,82/1037	58,46/1485	107,55/2732	20/500	162,87/4137	16,93/430	14,37/365	4,61/117	11,93/303	2.36 x 0.35/60 x 9	354.03/480

Reserves the right to change specifications without notice

OBX 02/15

Rev.1

ORBINOX CANADA, ORBINOX USA, ORBINOX BRAZIL, ORBINOX SPAIN, ORBINOX UK, ORBINOX FRANCE, ORBINOX GERMANY, ORBINOX INDIA, ORBINOX CHINA, ORBINOX S.E.A. EX (SER.10)\_15

www.orbinox.com

MODEL

EX

SERIES 10



FLANGE AND BOLTING DETAILS

ANSI B16.5 , class 150 (\*)

DN	K	n°	M	T	⊙ ⊕ ⊕
2"	4 3/4"	4	5/8" UNC	3/8"	4 - 0 - 0
2 1/2"	5 1/2"	4	5/8" UNC	3/8"	4 - 0 - 0
3"	6"	4	5/8" UNC	3/8"	4 - 0 - 0
4"	7 1/2"	8	5/8" UNC	3/8"	4 - 0 - 4
5"	8 1/2"	8	3/4" UNC	3/8"	4 - 0 - 4
6"	9 1/2"	8	3/4" UNC	1/2"	4 - 0 - 4
8"	11 3/4"	8	3/4" UNC	1/2"	4 - 0 - 4
10"	14 1/4"	12	7/8" UNC	3/4"	6 - 0 - 6
12"	17"	12	7/8" UNC	3/4"	6 - 0 - 6
14"	18 3/4"	12	1" UNC	7/8"	4 - 4 - 4
16"	21 1/4"	16	1" UNC	1"	6 - 4 - 6
18"	22 3/4"	16	1 1/8" UNC	1"	6 - 4 - 6
20"	25"	20	1 1/8" UNC	1"	8 - 6 - 6
24"	29 1/2"	20	1 1/4" UNC	1"	8 - 6 - 6
28"	34"	28	1 1/4" UNC	3/4"	12 - 6 - 10
30"	36"	28	1 1/4" UNC	3/4"	12 - 8 - 8
32"	38 1/2"	28	1 1/2" UNC	3/4"	12 - 8 - 8
36"	42 3/4"	32	1 1/2" UNC	3/4"	14 - 8 - 10
40"	47 1/4"	36	1 1/2" UNC	3/4"	14 - 12 - 10
42"	49 1/2"	36	1 1/2" UNC	3/4"	14 - 12 - 10
48"	56"	44	1 1/2" UNC	13/16"	26 - 10 - 8

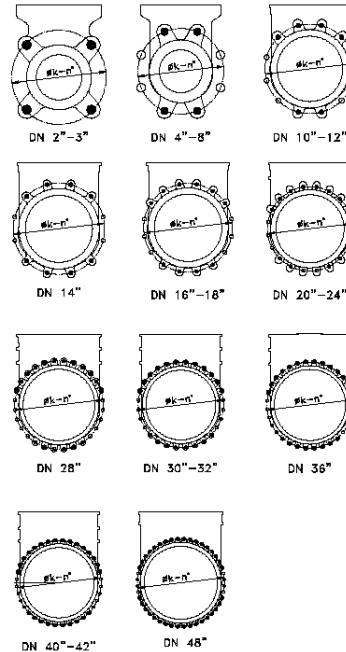

(\*) From DN 24", acc. To MSS SP 44 (class 150)

EN 1092-2 PN10

DN	K	n°	M	T	⊙ ⊕ ⊕
50	125	4	M-16	11	4 - 0 - 0
65	145	4	M-16	11	4 - 0 - 0
80	160	8	M-16	11	4 - 0 - 4
100	180	8	M-16	11	4 - 0 - 4
125	210	8	M-16	11	4 - 0 - 4
150	240	8	M-20	14	4 - 0 - 4
200	295	8	M-20	14	4 - 0 - 4
250	350	12	M-20	18	6 - 0 - 6
300	400	12	M-20	18	6 - 0 - 6
350	460	16	M-20	22	6 - 4 - 6
400	515	16	M-24	24	6 - 4 - 6
450	565	20	M-24	24	8 - 6 - 6
500	620	20	M-24	24	8 - 6 - 6
600	725	20	M-24	24	8 - 6 - 6
700	840	24	M-27	20	10 - 6 - 8
800	950	24	M-30	20	10 - 6 - 8
900	1050	28	M-30	20	12 - 8 - 8
1000	1160	28	M-33	20	12 - 8 - 8
1200	1380	32	M-36	30	22 - 6 - 4

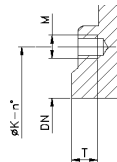

- BLIND TAPPED HOLES
- ⊕ TAPPED THROUGH
- ⊕ THROUGH HOLED

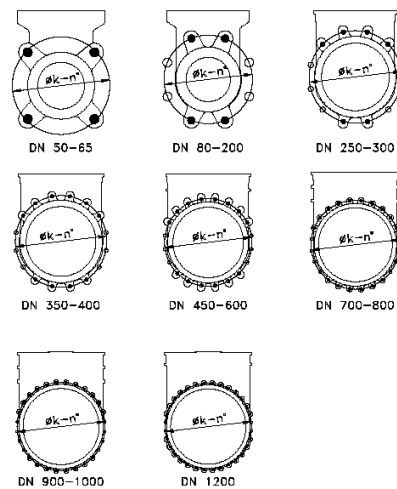

Reserves the right to change specifications without notice

ORBINOX CANADA, ORBINOX USA, ORBINOX BRAZIL, ORBINOX SPAIN, ORBINOX UK, ORBINOX FRANCE, ORBINOX GERMANY, ORBINOX INDIA, ORBINOX CHINA, ORBINOX S.E.A. EX (SER.10)\_16

www.orbinox.com

OBX 02/15

Rev.1