

DESCRIPTION

A range of float operated traps for draining water from compressed air lines.
Applications on aftercoolers , separators , compressed air mains.

MAIN FEATURES

Direct-acting float valve permits continuons drainage of water under changing conditions of inlet pressure and load. Because valve is under water during operation , air leakage is eliminated. Properly located it will assure a supply of dry compressed air.

OPERATION

Water entering the trap lifts the float and opens the discharge valve. This adjusts the valve opening so that there is a continuons flow of water throught the trap. There are no pressure fluctuations as the trap opens and closes.

NOTE

An equalizing line should be installed. This will equalize the pressure to the trap , eliminate gas binding and permit a smooth uninterrupted flow of condensate to the trap, the equalizing line connection to the tank must be above the level of any possible accumulation of condensate.

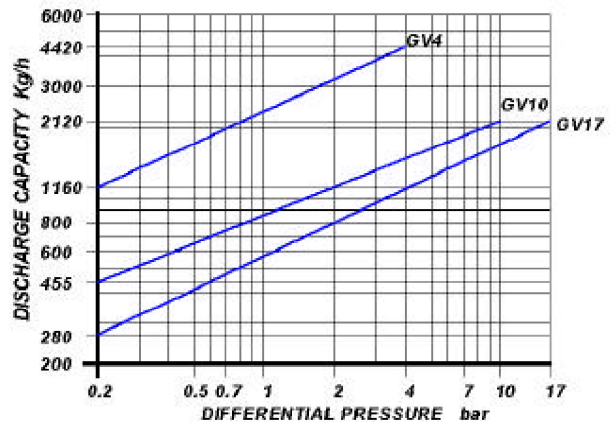
DISCHARGE CAPACITY

Safety factor = 1.2 – 1.5

SIZES

1"

CONNECTIONS

Screwed	BS 21 (BSP)
Flanged	ANSI 150# / 300# / UNI / DIN

LIMITING CONDITIONS (according to ISO 6552)

Steam Trap rating	DIN PN 25
PMA: Max allowable pressure	25 bar
TMA: max allowable temperature	300°C
PMO: max working pressure	17 bar
TMO: max working temperature	250°C
Max. Differential pressure (GV 4)	4 bar
Max. Differential pressure (GV 10)	10 bar
Max. Differential pressure (GV 17)	17 bar

COMPRESSED AIR BALL FLOAT TRAPS GV

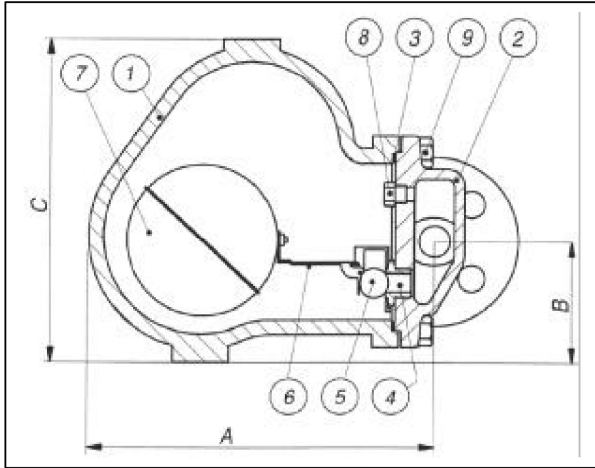

POS.	DESCRIPTION	MATERIALS	SPARES
1	Body	GGG40 (DIN 1693)	
2	Cover	GGG40 (DIN 1693)	
3	Gasket	CAF	X
4	Seat	AISI 410	X
5	Valve	AISI 304	X
6	Lever	AISI 304	X
7	Ball float	AISI 304	X
8	Plug	STAINLESS STEAL	
9	Bolts	8.8 (UNI 3740-74)	

Size (inches)	S	A	B	C	Weight (Kg)	Flanged					
						UNI-DIN PN16-25-40		150#		300#	
						SF	Kg	SF	Kg	SF	Kg
1"	165	238	81	218	13	215	16.5	210	16.5	214	16.7

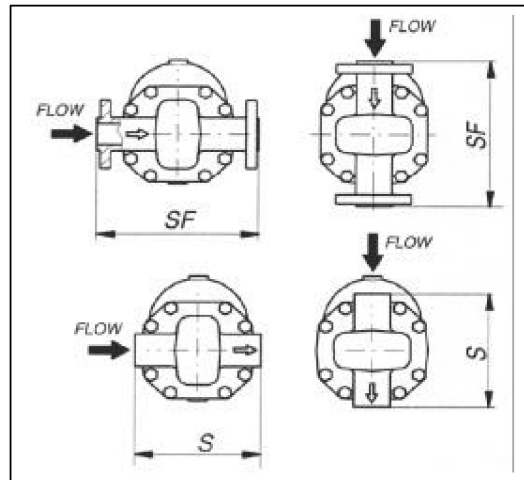

INSTALLATION

The steam trap must be fitted with the float arm in a horizontal plane so that it rises and falls vertically with the flow direction indicated on the body.

HOW TO SERVICE

By installing a new mechanism assembly (4),(5),(6), if necessary also a ball float (7), you can bring the steam trap to the "as new from factory" condition. This operation is carried out without removing the trap from the pipeline. Always fit a new gasket (3) when reassembling.

How to order: i.e. GV 17 ½" BSP

DOUGLAS ITALIA S.p.A Località Pradaglie – 29013 CARPANETO PIACENTINO (PC)

OFFICIAL WEB SITE: www.douglas-italia.com