

INVERTED BUCKET

This trap uses an inverted bucket that floats when steam is present and sinks when condensate exceeds a predetermined liquid level. When the bucket floats the valve – at the top of the trap – is closed. When it sinks the valve will open. On start up the bucket is down and the valve is wide open, when condensate and air enters the trap it flows directly into the bucket...The condensate falls into the trap body whereas air collects at the top of the bucket and causes it to float thereby closing the valve. Air is released through a vent at the top of the bucket and collects in the top of the trap until the bucket sinks opening the valve and allows the discharge of air and condensate. When steam is formed, it collects in the top of the bucket causing it to float thereby closing the valve. The bucket will sink again when condensate reaches the predetermined level and the cycle starts over.



MAIN FEATURES

Discharge of condensate at steam temperature. Simple and reliable construction. Slow discharge of air. Suitable for superheated steam. It with stands waterhammer.

APPLICATIONS

- Heater batteries
- Heat exchangers
- Pans
- Turbines
- Drying cylinders
- Ironing machines

DISCHARGE CAPACITY

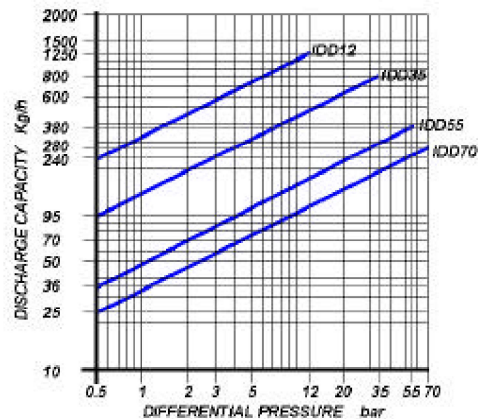

Cold water capacities are 2 to 4 times greater than the above.
Safety factor = 1.2 – 1.5

SIZES

½" – ¾" – 1"

CONNECTIONS

Screwed	BS 21 (BSP) / ANSI B1.20.1 (NPT)
Socket weld	ANSI B 16.11

LIMITING CONDITIONS (according to ISO 6552)

Steam Trap rating	ANSI 900
PMA: Max allowable pressure	155 bar
TMA: max allowable temperature	580°C
PMO: max working pressure	95 bar
TMO: max working temperature	480°C
Max. Differential pressure (IDD 12)	12 bar
Max. Differential pressure (IDD 35)	35 bar
Max. Differential pressure (IDD 55)	55 bar
Max. Differential pressure (IDD 70)	70 bar

INVERTED BUCKET STEAM TRAPS IDD F11

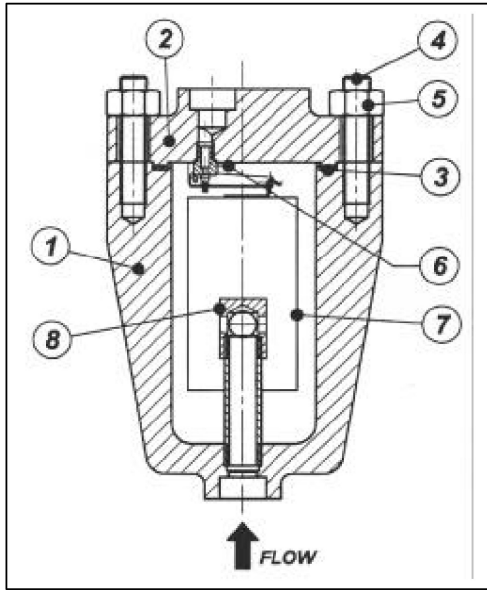

POS.	DESCRIPTION	MATERIALS	SPARES
1	Body	ASTM A182 F11	
2	Cover	ASTM A182 F11	
3	Cover gasket	316 / GRAPHITE	X
4	Studs	ASTM A193 L7	
5	Nuts	ASTM A194 Gr.4	
6	Seat	AISI 410	X
6	Valve	AISI 416	X
6	Lever	AISI 304	X
7	Bucket	AISI 304	X
8	Check valve *	AISI 304	X

* optional

Size (inches)	S NPT	S SW	A	B	Weight (Kg)
½"	305	305	18	155	23
¾"	305	305	18	155	23
1"	305	305	18	155	23

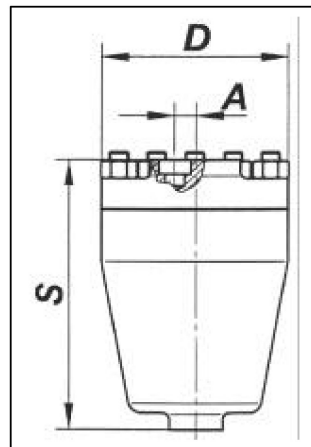

INSTALLATION

The trap must be installed with the body upright so that the bucket rises and falls vertically. The inlet and outlet connections must be in a horizontal position, with the trap installed below the drain point in order to form and preserve the internal water seal.

HOW TO SERVICE

Before doing any maintenance work always ensure that the trap is isolated and pressure is dissipated. Undo cover nuts (5), remove cover (2) with all mechanism and cover gasket (3). Unlock the bucket (7) from valve lever (6). Remove the valve guide undoing to the screw. Remove valve seat from cover (2). Screw in a new valve seat. Reinstall valve guide with lever and bucket (7). Refit cover (2), using new gasket (3).

How to order: i.e. IDD 12 ½" SW

DOUGLAS ITALIA S.p.A Località Pradaglie – 29013 CARPANETO PIACENTINO (PC)

OFFICIAL WEB SITE: www.douglas-italia.com