

STRAINERS

Designed to ANSI B16.34 the strainer bodies are produced with a superior wallthickness for corrosion allowance.

Standard strainers are equipped with screens for the average service of most mediums (steam, gas, air, oil, chemicals , ect.).

The large screen open area ensures an efficient filtering action with a low pressure drop.

Filtering area to inlet area ratio is larger than 3 to 1 .
Screens are manufactured with perforated plate in the materials and with the perforation specified in the relevant tables .

Screens with different perforation (or wire mesh) and materials may be manufactured on request.



INSTALLATION

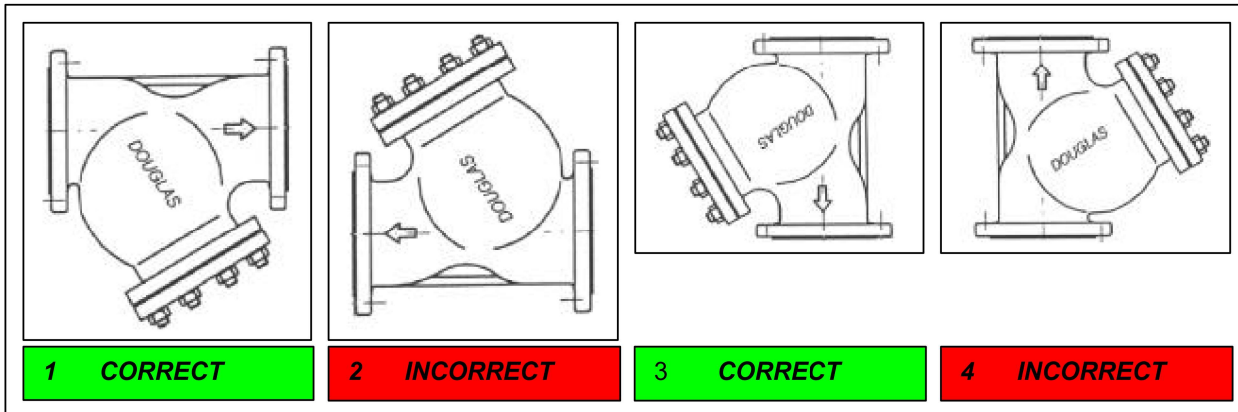

- All strainers should be mounted as close as possible to the valve or machinery which they are being installed to protect. It is important to ensure that the strainer installed with the flow following the same direction as the flow direction arrow cast onto the strainer body.
- For mounting in horizontal or inclined pipelines, ensure that the screen housing is always mounted below the pipeline.
- " Y " - strainers should never be installed in vertical pipelines in the upward flow condition. (see above)

SIZES

2"-3"-4"-6"-8"-10"-12"-14"-16"

CONNECTIONS

Buttweld	ANSI B16.25
Flanged	ANSI B 16.5

LIMITING CONDITIONS (according to ISO 6552)

According to the body rating (ANSI B16.34)
C600 - ANSI 600
OTHER RATINGS ON REQUEST

CAST STEEL "Y" TYPE STRAINERS DOUGLAS C600 CF8M

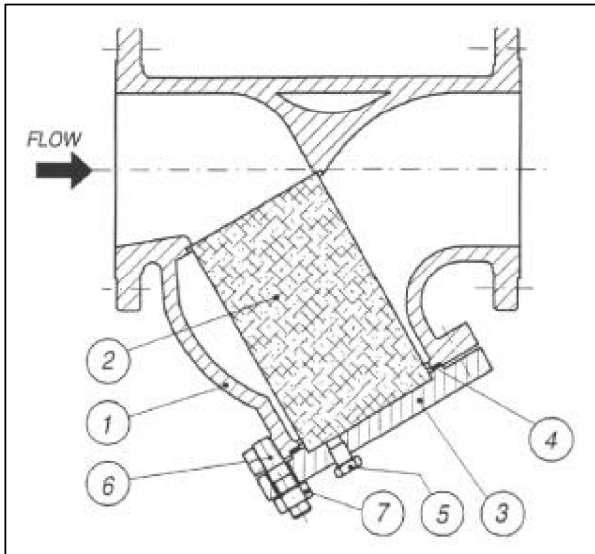

POS.	DESCRIPTION	MATERIALS	SPARES
1	Body	ASTM A351 CF8M	
2	Screen	S.S. 316	X
3	Cover	ASTM A240 316	
4	Gasket	316 / GRAPHITE	X
5	Drain plug	AISI 316	
6	Studs	ASTM A193 B8	
7	Nuts	ASTM A194 Gr.8	

OTHER MATERIALS ON REQUEST

Size (inches)	2"	3"	4"	6"	8"	10"	12"	14"	16"
SRTJ	295	259	435	562	663	790	841	892	994
SRF	292	356	432	559	660	787	838	889	991
S	292	356	432	559	660	787	838	889	991
H	193	260	310	400	500	600	720	865	1180
H1	270	320	400	530	650	790	1200	1420	1520
Kg	35	60	95	230	400	590	700	770	1140

STANDARD PERFORATIONS 1.5 mm
SPECIAL PERFORATIONS ON REQUEST . DRAIN PLUG SIZE 3/4"
Dimension : SRF , S , H , H1 are in millimeters (mm)

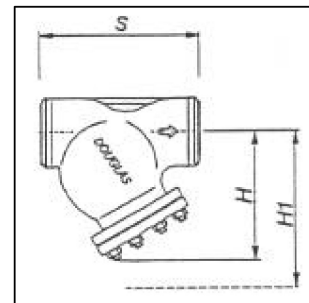
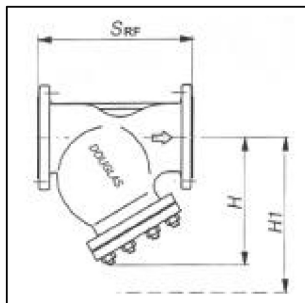
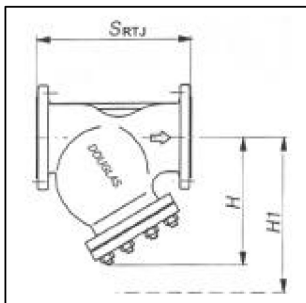

HOW TO SERVICE

Strainer maintenance should be made at least once year, or whenever the pressure drop is found to be in excess of the normal figures. A quick clean-up system, to made approximately once a month, is to blow-off small impurities through the drain-plug (5). It is recommended to install a drain valve by a nipple to the drain hole to speed-up this operation. For a complete maintenance follow the points herebelow: **-1-** Be sure that the main line has been shut-off. **-2-** Untighten cover stud bolts (6) and nuts (7) and remove cover (3) and gasket (4). **-3-** Withdraw screen (2) and carefully inspect it for damages. If any hole in the screen is found obstructed, clean it with compressed air and / or any suitable tool. If the screen is broken in any part or out of shape, replace it with a new spare one. **Never reinstall a broken or distorted screen.** **-4-** Carefully clean the inside of the strainer body. **-5-** Fit a new gasket (4). **-6-** Install the new screen or the cleaned one (2). Be sure to center the screen in the upper seat. **-7-** Put in place cover (3). Be sure that drain plug (5) is closed. **-8-** Slowly give pressure to the line, checking for leakages. **9-** Write on the strainer body the date of this maintenance operation.

How to order: i.e. C600 CF8M / 316 F 1.5 2" 600 RF

DOUGLAS ITALIA S.p.A Località Pradaglie – 29013 CARPANETO PIACENTINO (PC)

OFFICIAL WEB SITE: www.douglas-italia.com